

DESCRIPTION

Specially designed trolley for handling Protectiles tiles:
 - 4 swivel wheels with rubber bands and 2 brakes on the rear wheels.



PROPERTIES	STANDARDS	PROTECTILES TROLLEY
GENERAL CHARACTERISTICS		
Length	-	2003mm
Width	-	1003mm
Height	-	1051mm
Composition of the wheel	-	Rubber
Diameter of the wheel	-	200mm
Dynamic load on sports floor*	-	434kg (70 tiles maximum)
Static load in storage area**	-	620kg (100 tiles maximum)
PACKAGING		
Total weight	-	Approximately 60kg
Minimum quantity	-	1 trolley

TECHNICAL DRAWING

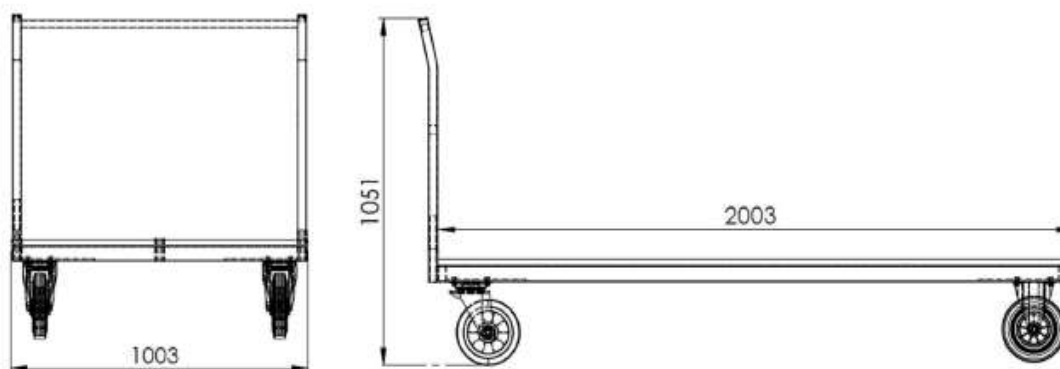

* Maximum load to facilitate the movement of the trolley and avoid damaging the surface of the sports floor.
 ** Storing the loaded trolley on soft sports flooring is prohibited.

Technical data valid as of the publication date (10/2024).

The values above correspond to laboratory tests test (no in situ test) and are subject to change for the benefit of new improvements.
 For more detailed technical information, please contact Tarkett Sports.

The colours of the products shown in the photos or samples are for indicative purposes only. There may be differences in colour, gloss, and texture between the products sold and the photos or samples.