



Vinyl Nosings

Product Specification

1. PROPRIETARY PRODUCT/MANUFACTURER

1.1. Proprietary Product: : Resilient Vinyl Stair Nosings

1.1. Manufacturer:

Tarkett North America Phone: (800) 899-8916
30000 Aurora Rd. (440) 543-8916
Solon, Ohio 44139
Web: www.tarkett.com

1.2. Proprietary Product Description:

1.2.1. **Construction:** Tarkett Vinyl Stair Nosings are manufactured from a homogeneous composition of polyvinyl chloride (PVC), high quality additives, and colorants to meet the performance requirements of ASTM F-2169 Standard Specification for Resilient Stair Treads, Type TV, Class 1 and 2, Group 1 and 2. Standard formulation exceeds ASTM E648 Class 1 Flammability requirements. Tarkett Vinyl Stair Nosings are designed for interior applications only and not recommended for commercial kitchen environments.

1.2.2. Styles & Physical Characteristics:

(See Table on pages 2 & 3)

- **Length:** 12 ft. (3.66 m)
- **Packaging:**
 - VIRCN and SRCN-A: 72 ft. (21.95 m) per carton
 - VCD and SVCD: 60 ft (18.29 m) per carton
 - SVCD-A and SRCN-C: 48 ft. (14.6 m) per carton
 - ALL OTHERS: 120 ft. (39.58 m) per carton

2. PRODUCT PERFORMANCE AND TECHNICAL DATA

- 2.1. **Slip Resistance:** ASTM D 2047 - Exceeds Federal Standards and ADA recommendations of .6 for flat surfaces
- 2.2. **Fire Resistance:** ASTM E 648/NFPA 253 (Critical Radiant Flux) - Class 1
- 2.3. **CAN/ULC S102.2:** FSR 70 / SDC 555

3. INSTALLATION

- 3.1. See Stair Tread, Nosing, Riser, and Stringer installation instructions for complete details.
- 3.2. **Adhesives:**

- **Tarkett 946 Premium Contact Adhesive Coverage:**

Non-porous Substrate:

1 quart unit (0.95 liters) – 24 to 36 sq. ft.

1 gallon unit (3.79 liters) – 144 to 215 sq. ft.

- **Tarkett 930 Two-part Epoxy Nose Caulk Coverage:**

13.5 oz. cartridge, with #530 Caulking Gun at a 1/4" diameter bead – approximately 50 linear feet.

4. AVAILABILITY AND COST

Available through authorized Tarkett distributors nationwide.

5. MAINTENANCE

72 hours after installation is completed, initial maintenance procedures must be implemented in accordance with manufacturer's requirements. Refer to vinyl nosing maintenance instructions for complete details.

6. TECHNICAL SERVICES

Visit us on the web at www.tarkett.com

Contact Technical Support at (800) 899-8916 or E-mail:

Resilient.TechnicalSupport@Tarkett.com

Samples: Submittal samples for verification and approval available upon request from Tarkett. Samples shall be submitted in compliance with the requirements of the contract documents. Accepted and approved samples shall constitute the standard materials which represent materials installed on the project.

7. WARRANTY

Limited 5-year warranty. For complete details, contact Tarkett or an authorized Tarkett distributor.

Tarkett North America

Technical Services Department
30000 Aurora Road
Solon, Ohio 44139
800.899.8916
info@tarkettna.com

www.tarkett.com

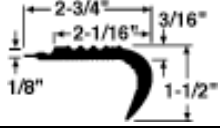
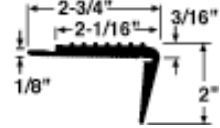
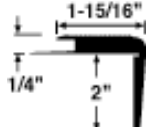
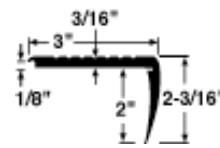
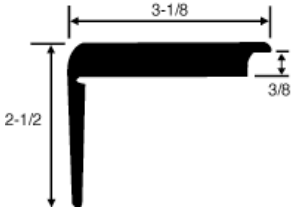
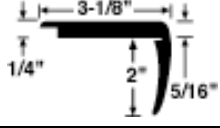
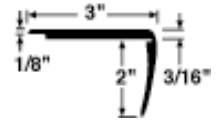
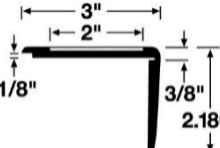
Product Code	Profile	Flooring Thickness	Length	Pieces Per Carton	Weight Per Carton
VDL XX RD Round Vinyl Stair Nosing		1/8" on stair	12 ft.	10	60 lbs.
VDL XX SQ Square Vinyl Stair Nosing		1/8" on stair	12 ft.	10	73 lbs.
RCN XX A Recessed Vinyl Stair Nosing		1/4" and 5/16" on stair	12 ft.	10	73 lbs.
RCN XX B Recessed Vinyl Stair Nosing		1/8" with lip, 3/16" without lip on stair	12 ft.	10	69 lbs.
SRCN XX C For Thicker Carpeting on Steps.		3/8" on stair	12 ft.	4	60 lbs.
VIRCN XX A Visually Impaired Recessed Vinyl Stair Nosing		1/4" to 5/16" on stair 2" contrasting Visually Impaired strip.	12 ft.	6	67 lbs.
VIRCN XX B Visually Impaired Recessed Vinyl Stair Nosing		Overlap lip for 1/8" material with lip, 3/16" without lip 2" contrasting Visually Impaired strip	12 ft.	10	62 lbs.
VIRCN XX B2 Visually Impaired Recessed Vinyl Stair Nosing		1/8" on stair 2" Visually Impaired Grit Tape Insert	12 ft.	10	75 lbs.



Tarkett North America

Technical Services Department
30000 Aurora Road
Solon, Ohio 44139
800.899.8916
info@tarkettna.com

www.tarkett.com

Vinyl Nosings

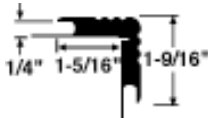
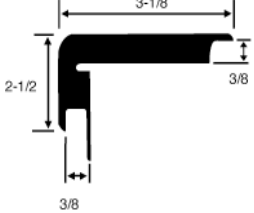
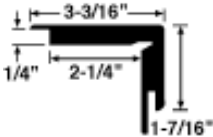
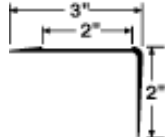
Product Specification

<p>VCD XX Double Undercut Carpet Stair Nosing</p>		<p>1/4" & 5/16" on stair and riser, with ribbed surface.</p>	<p>12 ft.</p>	<p>10</p>	<p>76 lbs.</p>
<p>SVCD XX A For Thicker Carpeting on Step and Riser</p>		<p>3/8" on stair and riser</p>	<p>12 ft.</p>	<p>4</p>	<p>60 lbs.</p>
<p>VIVCD XX Visually Impaired Double Undercut Stair Nosing</p>		<p>1/4" and 5/16" on stair and riser 2" contrasting Visually Impaired strip.</p>	<p>12 ft.</p>	<p>5</p>	<p>55 lbs.</p>
<p>VITSN XX Visually Impaired Top Set Stair Nosing</p>		<p>Top set on bare concrete, wood, steel. 2" contrasting co-extruded strip.</p>	<p>12 ft.</p>	<p>10</p>	<p>50 lbs.</p>
<p>DTN XX Over/Top Stair Nosing</p>		<p>Top set residential stair nosing.</p>	<p>12 ft.</p>	<p>10</p>	<p>27 lbs.</p>

Tarkett North America

Technical Services Department
30000 Aurora Road
Solon, Ohio 44139
800.899.8916
info@tarkettna.com

www.tarkett.com