

iD Click Ultimate

30, 55 & 70

LUXURY VINYL TILES

Natural
designs and
ultimate
performance.

Contents

2 Introduction

8 Design

16 Naturals

46 Authentics

54 Classics

72 Performance

86 Sustainability

92 Selection Guide

**94 Formats &
Customisation**

**96 General
Characteristics**



Have it all

Challenging the conventional wisdom that good things always come with some form of compromise, Tarkett introduces the Tarkett iD Click Ultimate line. Imagine a rigid flooring solution that combines the practical benefits of vinyl with the splendour and awe-inspiring qualities of natural materials such as stone and wood. A lush, oak floor resistant to staining, to shocks, even to water. Or imagine a limestone hallway, indiscernible from genuine lime, installed in a matter of hours, yet ready to last for years and years of heavy use. With acoustic qualities that defy the ear, muting hard heels to soft patter.

Can you imagine it? We can. So we made it.
With Tarkett iD Click Ultimate you really can have it all.

iD Click Ultimate

iD Click Ultimate takes rigid surface flooring to the next level. Now, you can combine the look, feel and strength of wood and stone with all the advantages of luxury vinyl tiles. Easily installed on almost all surfaces - even ceramic tiles - iD Click Ultimate allows you to deliver perfect installations and meet your project's and client's requirements in minimum time.

Driving this evolution is our improved Rigid Composite Core+ (RCC+) technology, providing unparalleled resistance to shocks and heavy loads and improving dimension stability. Our GenClick® locking system leverages this technology in iD Click Ultimate tiles, making them fit for use in any and all surroundings, even bathrooms. To meet the challenges set by high-traffic areas in particular, Tarketts

proprietary TEKTANIUM™ coating guarantees easy maintenance and unequalled protection of its eye-catching ultra matt finish. In addition, Soundblock acoustic backing reduces harsh heel to floor sounds to a near whisper.

Matching this new standard in rigid surface flooring, our new Digital Printing Technology produces designs of next-level realism: scanned directly from the natural wood and stone patterns that inspired them and reproduced in high definition with minimal repetition, they bring nature's wholesome qualities where they are needed.

Available in five formats and 43 designs and backed by a versatile customisation service, iD Click Ultimate really has it all.



1 Design

From beautifully grained wooden planking to natural stone tiles, recreated to the finest detail... Seeing the quality and near endless design options our digital printing technology offers, you may find yourself having a hard time to choose.

2 Performance

Exquisite form must be followed by impeccable function. iD Click Ultimate fully delivers, combining extreme durability with unparalleled sound absorption and water resistant qualities in easy to install tiles.

3 Sustainability

Respect for the environment and the natural world that inspires us will always be a driving force in our development and innovation efforts. With our manufacturing exclusively in the EU, we continue to push for even lower emissions, even better circularity and to drive sustainability further in all of our operations.

Design

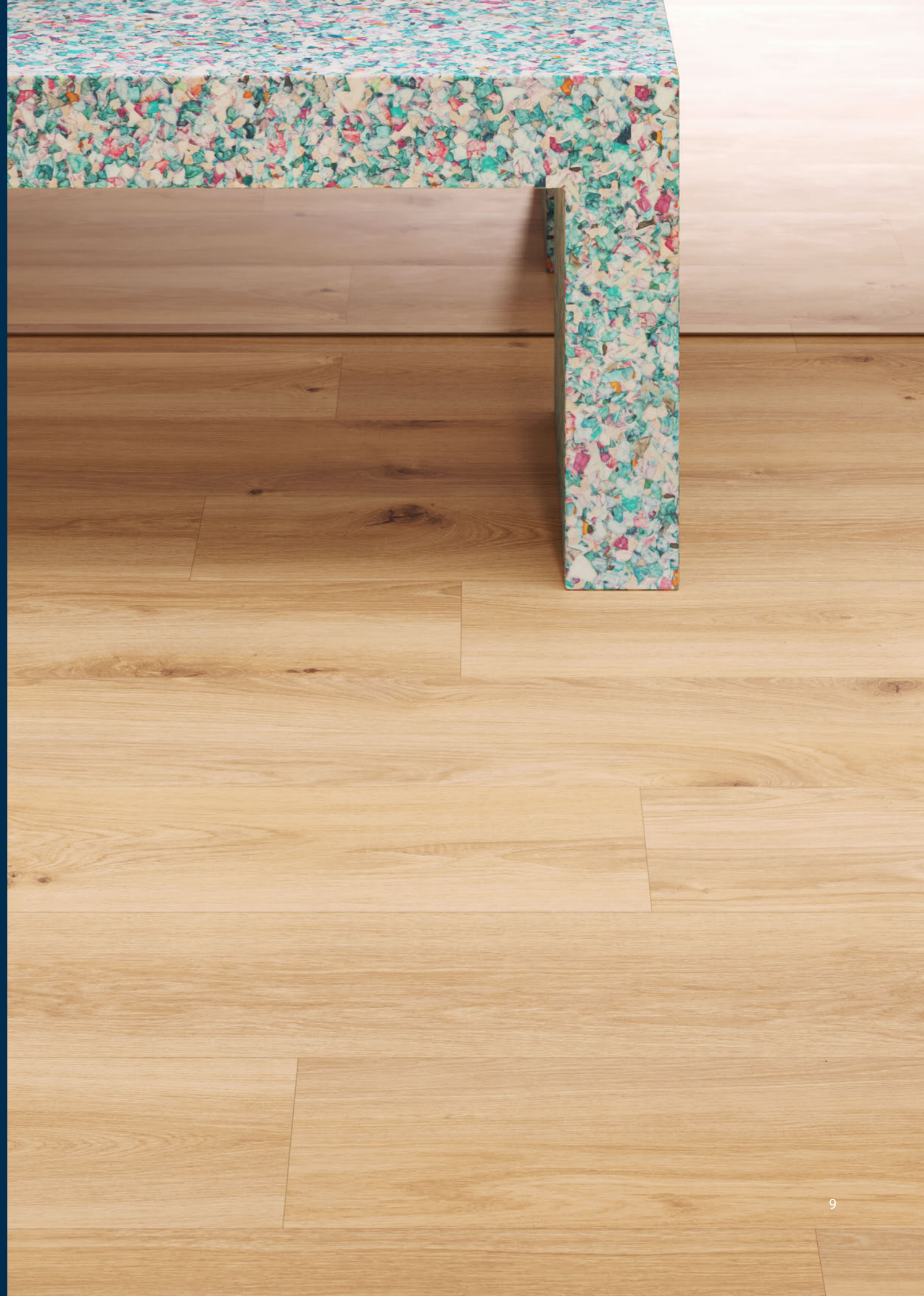

1

Unrivalled Wood & Stone designs

The new iD Click Ultimate sets an unprecedented milestone in the design of modular vinyl collections. Our advanced digital printing technology enables us to reveal the most subtle details of wood and stone to make each plank or tile unique in grain, texture and colour. Most importantly, it enables specifiers to choose the best of natural designs embedded in the highest-performing vinyl materials.



Bringing the outdoors inside

Designing spaces has moved definitively towards connecting interiors with the outdoor world, echoing the beauty of nature to improve quality of life in urban spaces. By selecting the best natural tones of woods and expressive stones, we have sought to bring the outdoors in.

In this way, we aim to create positive emotions to help enhance learning, working and caring. iD Click Ultimate decors were selected to foster a feelgood atmosphere, and bring interior designs to life through the use of our exclusive digital printing technology.

Meanwhile, we have continued to focus on modularity and flexibility, with the introduction of oversize format. The end result is a palette of designs, echoing authentic building materials, that enables you to create people-friendly spaces.

Capturing the beauty of wood and stone

Nature guides every aspect of our design journey. We have taken our design sourcing process to the next level, carefully making selections based on character, detail and natural diversity of expression. Every design in the Naturals collection is scanned directly from a chosen specimen of wood or stone, from oak to limestone. By paying attention to the origins of these natural materials, we share with you the wonder of natural imperfections and nuances. The variety of our designs gives you the freedom to subtly match the style that best suits your space.

iD Click Ultimate is designed to make your flooring creation process easy.

43
Decors

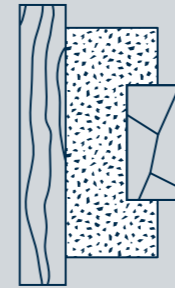

Naturals
Authentics
Classics

3
Printing
technologies

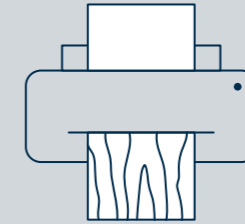

Digital printing
Embossing in register
Rotogravure

3
Wear
layers

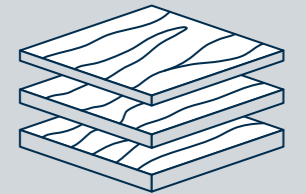

0.30 - Class 23/31
0.55 - Class 23/33
0.70 - Class 23/34

5
Formats*

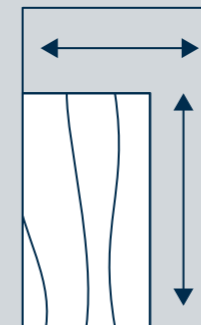

24.30x150cm
30.60x120cm
20.05x120cm
32x64cm
48x96cm

2
Customisation
services

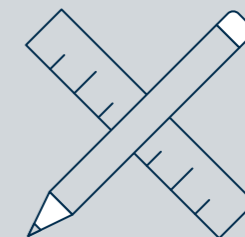

Pre-defined service
A la carte service

**Formats are specific per design. Please go to customisation if your chosen format is not available as standard.*

NATURALS

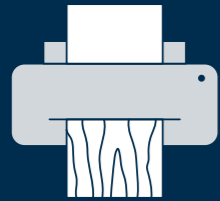

Designing as nature intended

Scanned from nature through the meticulous sourcing of high quality raw materials, our Naturals designs display a high definition with non-repeating motifs for up to 12 m².

AUTHENTICS



Synchronising look & feel

This technology engraves effects onto planks and tiles. The embossed pores perfectly echo the high definition printed image, resulting in finishes that are evermore realistic.

CLASSICS

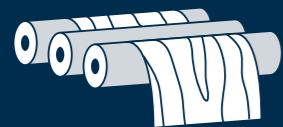

Trusting in our origins

Classic gravure printing showcases our most acclaimed materials and colour harmonies.





Naturals

Designing as nature intended

Our Naturals designs are scanned from nature through the meticulous sourcing of high quality raw materials such as wood and stone. Using a unique patentprotected digital printing technology, the only single-pass 2m wide printer for jetting water-based inks on vinyl in the world, we have reflected the best of nature's diverse features, from characterful wood grains to the subtle textures and nuances of stone. To convey the true diversity of the natural world in all its glory, our modular vinyl flooring displays a high definition with non-repeating motifs and an ultra matt finish.

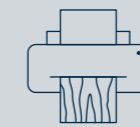

**HIGH
DEFINITION**



**NO
REPEAT**



**BIGFOOT
FORMAT**

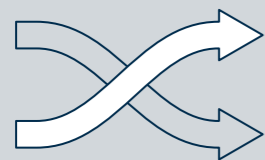

NO REPEAT

12 m²

TARKETT NATURALS

No repeat up to 50 planks
20.05cm x 120cm format

Our Naturals designs display
a high definition with non-repeating
motifs up to 12m²

3 m²

STANDARD LVT: 3m²

No repeat up to 10 planks
20.05cm x 120cm format



Let us
inspire you

Brushed Elm brown
Sediment beige



Sediment beige
Brushed Elm brown
Forest Oak pistachio shell
Patina Concrete light grey



Brushed Elm brown
Sediment beige



Personalise
your space

Terrazzo Classical emerald (customisation)
Creek Oak beige



Terrazzo Classical emerald (customisation)
Creek Oak beige
Concrete indiun
Vintage Zink silver
Terrazzo Classical jade (customisation)
Terrazzo Classical opal (customisation)



Terrazzo Classical emerald (customisation)
Creek Oak beige



Create the right atmosphere



Chatillon Oak natural
Antik Oak beige
Delicate Oak toffee
Delicate Oak sugar
Highland Oak arabica
Emperador grey
Emperador green



Chatillon Oak natural





Connecting
people



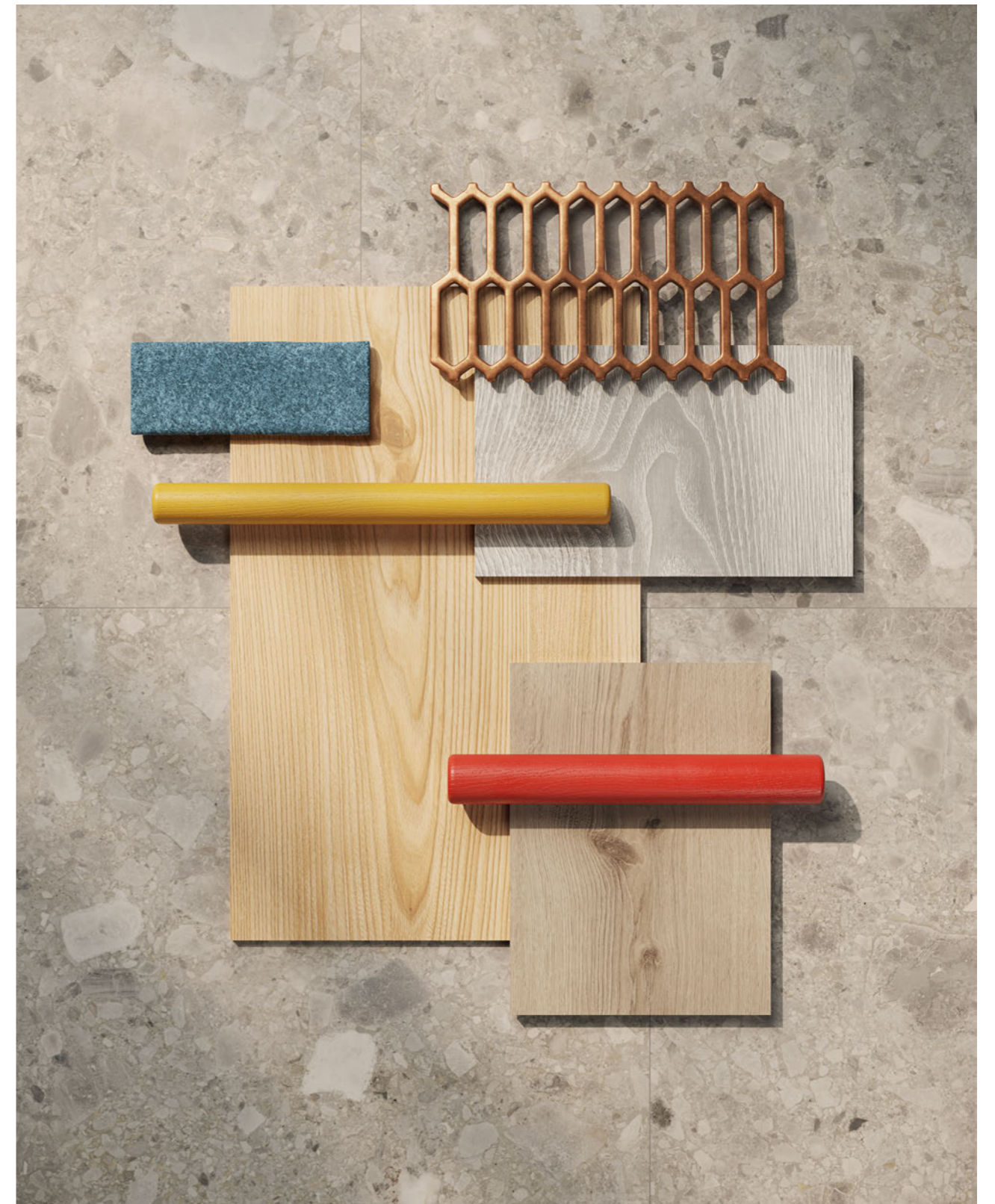

Breccia grey
Brushed Elm natural
Delicate Oak clay
Scandinavian Oak medium grey



Breccia grey



Colour Chart

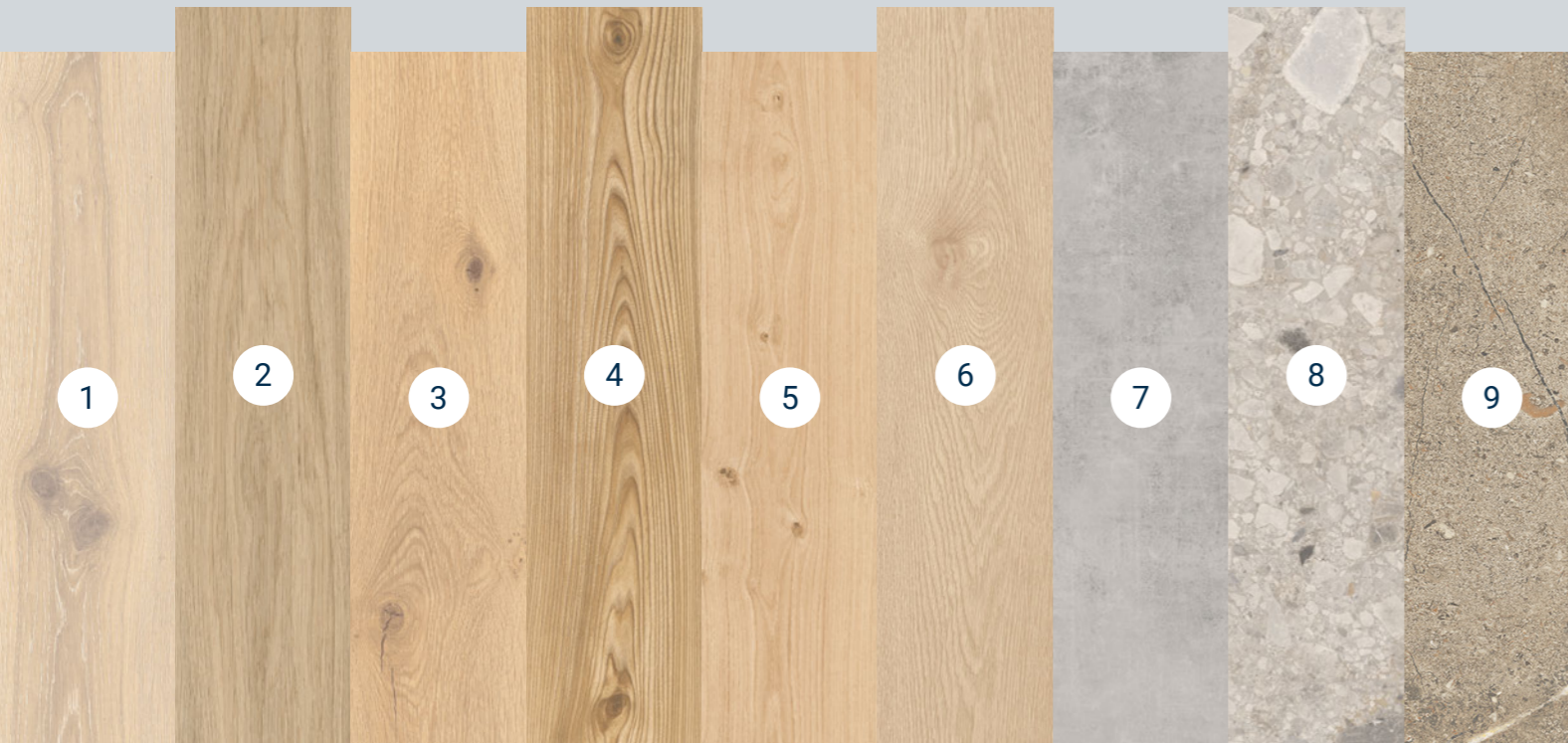

- 1 Forest Oak
- 2 Variant Oak
- 3 Creek Oak
- 4 Brushed Elm
- 5 Nomad Oak
- 6 Chatillon Oak
- 7 Patina Concrete
- 8 Breccia
- 9 Sediment

Forest Oak



Variant Oak



Creek Oak



CU Click Ultimate: Available on stock
55 0.55: Available on stock
70 0.70: Available on stock

Brushed Elm



Nomad Oak



Chatillon Oak



Patina Concrete

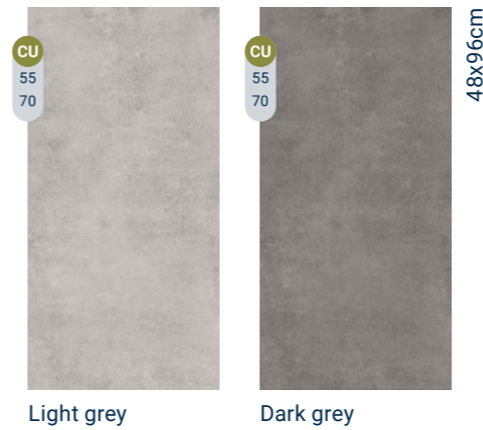

Breccia



Sediment





Authentics

Synchronising look & feel

Our Authentics designs are created with “Embossing in register” technology for a more natural look. This technology engraves effects onto planks and tiles to reproduce unique flooring that gives a truly realistic impression of real wood.



7 DIFFERENT
COLOURS



REALISTIC
IMPRESSION



2 NEW
DESIGNS

Echo the beauty
of nature

Highland Oak golden



Rock grey
Highland Oak golden
English Oak brown
Vintage Zinc black

Colour Chart



- 1 Delicate Oak
- 2 Highland Oak

Delicate Oak



Highland Oak



- CU Click Ultimate: Available on stock
- 30 0.30: Available on stock
- 55 0.55: Available on stock
- 70 0.70: Available on stock



Highland Oak golden



Classics

Trusting in our origins

Classic gravure printing has stood the test of time for decades. For this collection, our designers have selected our most acclaimed materials and colour harmonies to help you develop feel-good interiors.

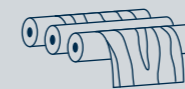

ROTOGRAVURE

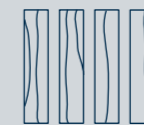

9 BEST IN
CLASS DESIGNS

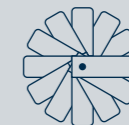

28 COLOURS



Rock grey

Create people-
friendly spaces



Contemporary Oak grege



Create a calm atmosphere

Composite cool grey



Composite cool grey



Bring interior designs to life



Scandinavian Oak medium beige



Colour Chart



- 1 English Oak
- 2 Contemporary Oak
- 3 Scandinavian Oak
- 4 Rustic Oak
- 5 Antik Oak
- 6 Rock
- 7 Composite
- 8 Polished Concrete
- 9 Vintage Zinc

English Oak



CU Click Ultimate: Available on stock
 30 0.30: Available on stock
 55 0.55: Available on stock
 70 0.70: Available on stock

*Format 20.50x120cm
 for iD Click Ultimate 30
 **Format 32x64cm
 for iD Click Ultimate 30

Contemporary Oak



Scandinavian Oak



Rustic Oak



Antik Oak



Rock



Composite



Polished Concrete

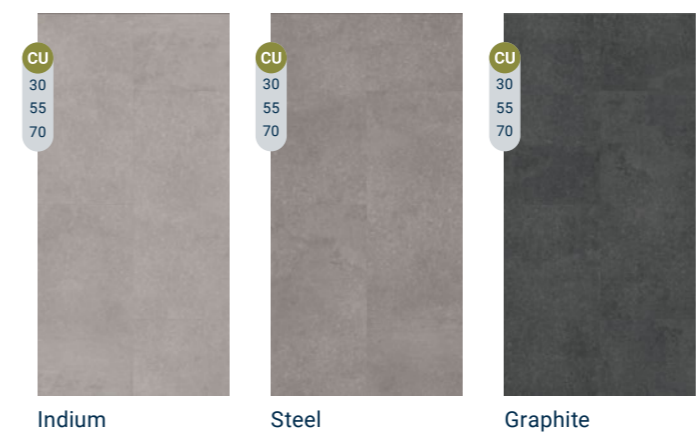

Vintage Zinc



Performance

2



The new vinyl tile generation a concentrate of technology



1

TEKTANIUM™ PU coating: ultra matt finish protected by unequalled resistance.

2

Wide range of designs partly created with our Digital Printing Technology makes for an extensive range of design possibilities - including high definition graphics and embossing - to choose from, expanded even further with excellent customisation options.

3

RCC+ takes SPC flooring to the next level. It provides superior durability and stability through its advanced Rigid Composite Core+ technology, made possible through the cutting edge co-extrusion production process. Its triple-layer construction and carefully engineered formula provides unparalleled resistance to heavy traffic and exceptional dimensional stability.

4

Acoustic backing featuring Soundblock technology absorbs 19dB of impact noise.

5

When combined with the water-resistant properties of RCC+, our GenClick® makes for a watertight product, able to resist water for more than five days without leakage.

TEKTANIUM™

Best ultra matt finish and unequalled resistance

The iD Click Ultimate collection features our new TEKTANIUM™ PU coating which uses a proprietary polymer system -forming a naturally clear, verifiably stronger layer of protection that delivers unequalled resistance to scratches, abrasions, wear, stains and is the easiest to clean. Moreover, it offers a pure ultra matt finish, which is consistently visible from all angles. By mixing ultra matt effect with excellent resistance and durability properties, the surface of your flooring appears more realistic and lasts longer. TEKTANIUM™ is the only PU coating to combine all these features, so there's no need for compromise.

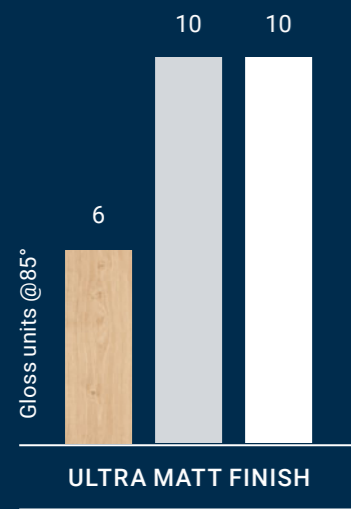

Gloss measurement at an 85° angle (in compliance with ISO 2813).

≤ 6 = ultra matt
≥ 10 = satin

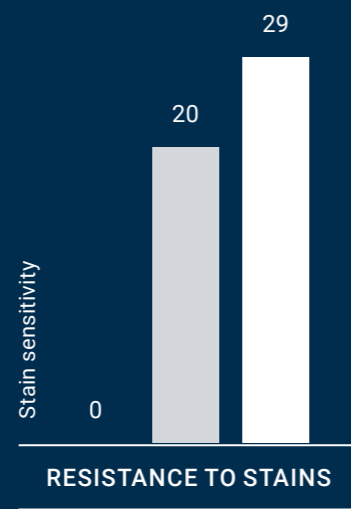

Stain resistance measurement (in compliance with ISO 26987).

0 = not affected (best in class)
30 = very affected

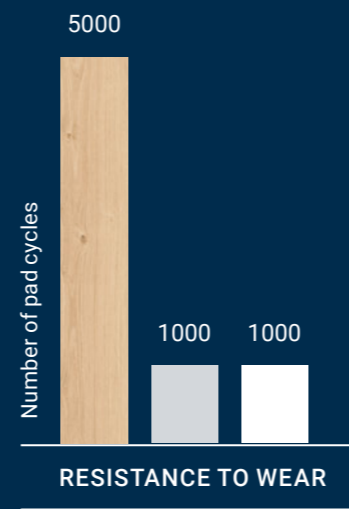

Wear resistance measurement (based on EN ISO 16094).

5000 = best in class

- Tarkett: iD Click Ultimate
- Key European competitor A
- Key European competitor B

GenClick®

The next generation locking system

GenClick® is our patented locking system, co-developed with our RCC+ core layer technology to offer easy installation without sacrificing locking strength and mechanical properties for best performance, resistance and durability.

GRAPH 1: LOCKING STRENGTH (ISO 10582)
HIGHER LOCKING STRENGTH SCORE = STRONGER CONNECTION

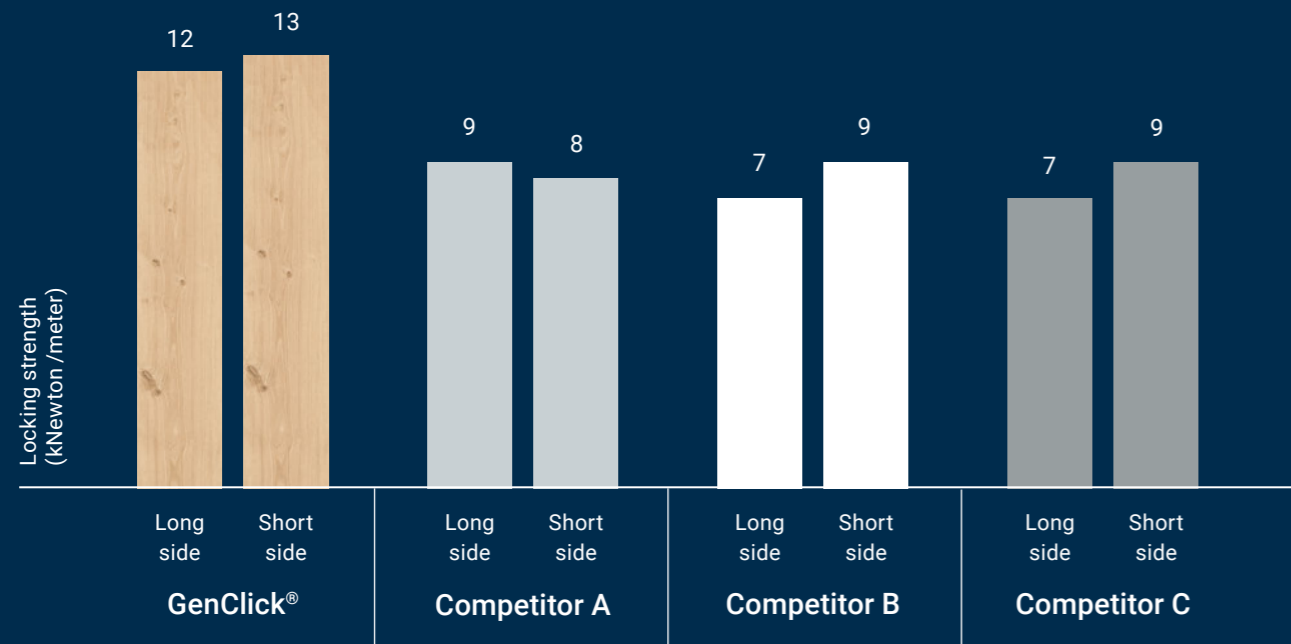

GRAPH 2: IMPACT RESISTANCE (INTERNAL TEST)
LOWEST SCORE = HIGHEST RESISTANCE TO IMPACT

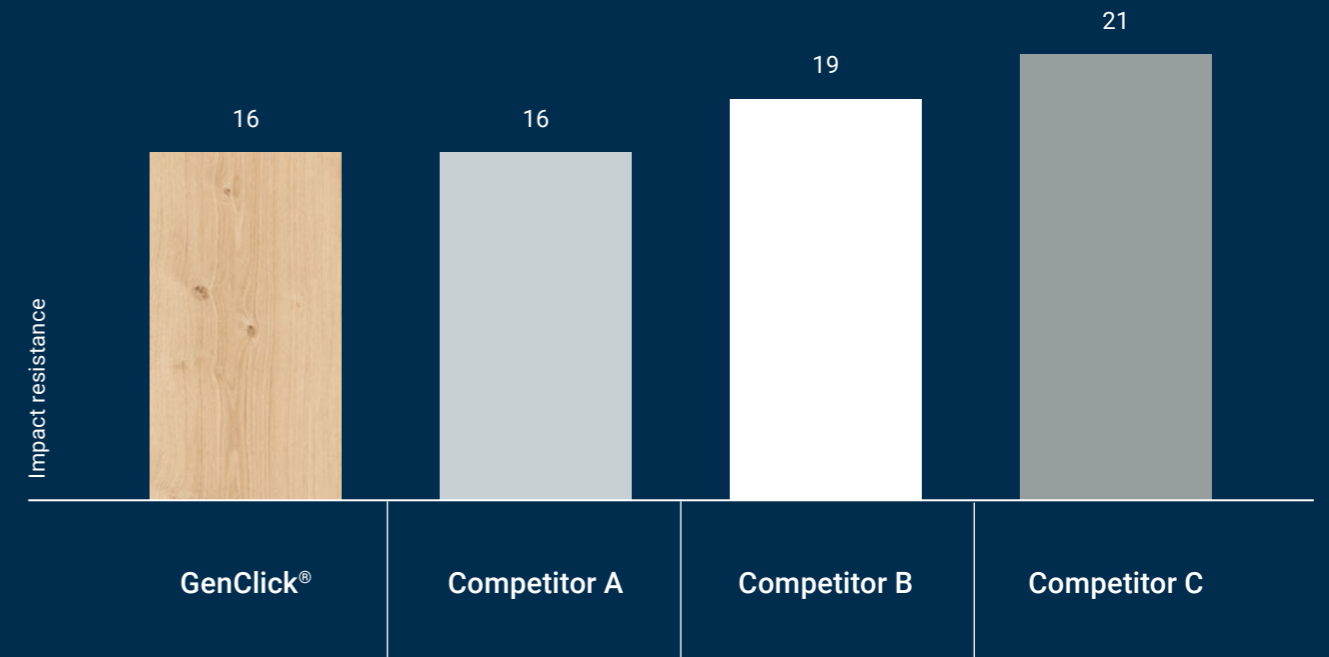

Easy installation

With the Angling and Push Down locking combination you can easily position the long side of the product with an angling motion and tap into place the short side.

Market leading locking strength

GenClick® locking strength is the best in class according to ISO 10582 (Graph 1).

Resistance to shocks

iD Click Ultimate is strong and resistant to shocks as verified by Impact resistance internal test (Graph 2).

Watertight Click

The Click geometry does not allow water to leak through the joints. This makes the product suitable for installation in bathrooms.

Toughen up your floors for intense use

Ultimate
Resistance

iD Click's Ultimate's extra density **RCC+** technology* delivers in every dimension

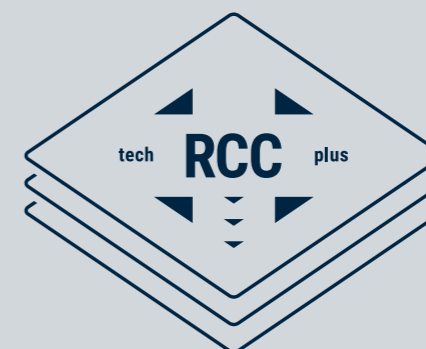

Wear-proof & water-proof

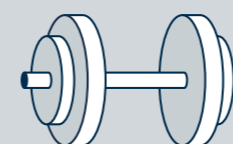

Ideal to cover spaces up to 400m² and withstand high traffic. RCC+ technology has a triple layer construction and the highest density on the market making it the most resistant to sustain indentation and heavy loads, even with high temperature variations (10 to 60°C)**.

Best performance

GenClick®
TEKTANIUM™

Combined with our new and patented GenClick® locking system and TEKTANIUM™ PU coating we provide the best performance in dimensional stability, resistance and durability.

Suitable for bathrooms

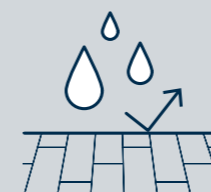

RCC+ is a waterproof technology and GenClick® is our watertight locking system. iD Click Ultimate withstands water without any leakage and has a high slip resistance (R10).

*Only iD Click Ultimate 55-70

**10°C to 50°C and 225m² (15x15) for iD Click Ultimate 30

Soak up through the floor

Ultimate Acoustics

Noise-proof



Reduce in-room and impact noise from rolling and walking. 19dB impact sound reduction thanks to Soundblock technology. Save money with iD Click Ultimate integrated acoustic backing. No need for additional acoustic underlay.

Decrease in-room sound



The exclusive structure of iD Click Ultimate ensures the lowest in-room walking noise compared to any other hard floor solution.

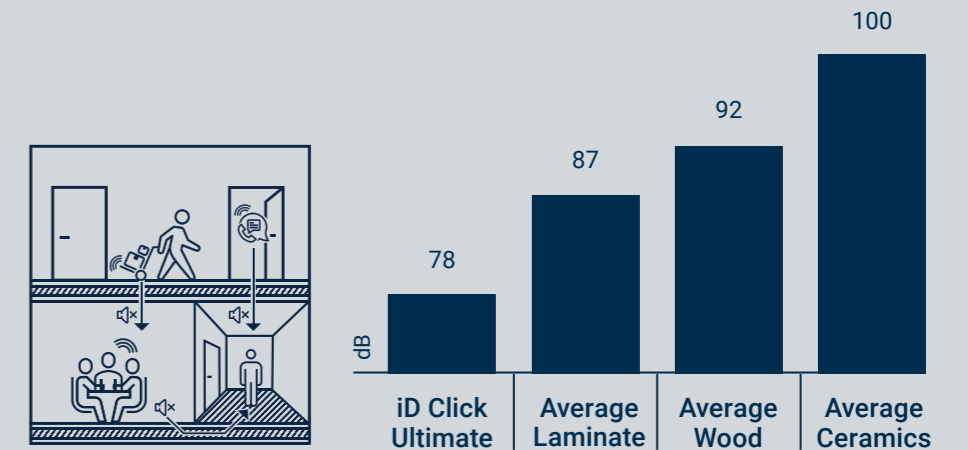

Elevate your living experience with Class C Reduction of in-room impact noise (NF S31-074). Enjoy a peaceful and tranquil environment with superior sound insulation and enhanced comfort.

Save money



With iD Click Ultimate integrated acoustic backing, no need for additional acoustic underlay.

Open up your space for immediate use

Ultimate Installation

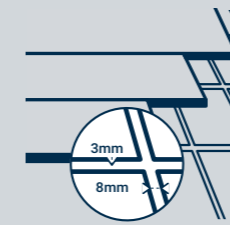

Renovation-proof

Install directly over ceramic tiles and most existing subfloors. Quick and easy installation thanks to GenClick® locking system. Minimize downtime and use immediately.

Foam backing

Our iD Click Ultimate tiles have a foam backing that covers subfloor imperfections. For a perfectly even floor.



Click it quick and easy



With the Angling and Push Down locking combination you can easily position the long side of the product with an angling motion and tap into place the short side.

Install and walk

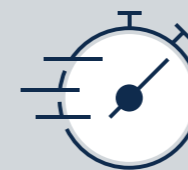

Everything about iD Click Ultimate makes it fast to install and ready for immediate use. No glue, no drying time. Up to 400m² with no expansion profiles (spaces of 20x20m)*.

*15x15m and maximum 6x3mm ceramics joints for iD Click Ultimate 30

Sustainability

3





Conscious choices. For people & planet.

The pursuit of 'always more' is pushing our limits and threatening our planet. The game must change. We need to find a way to deliver more with less. For us, this means less waste, lower emissions, greater well-being and more proof.

The way to better floors.

Climate and circular economy. Less waste, lower emissions.

We are passionate advocates of the circular economy. It's why we're working to maximise the recycled content in all our products and prioritise end-of-life recycling.



RECYCLED CONTENT

Our designs contain on average 20% of recycled content according to ISO 14021.



RECYCLABILITY

iD Click Ultimate installation and post-use waste is recyclable through our ReStart® take-back and recycling programme.



MADE IN EUROPE

Our iD Click Ultimate collection is manufactured in-house at our European production site in Jaslo (Poland).



CLIMATE CHANGE

In 2021, 15% of the total volume of our purchased raw materials were recycled, avoiding 280,000 tonnes of CO2*.

**Estimation for part of scope 3.*

Good indoor air quality. Greater wellbeing.

Our commitment to giving you healthier spaces to live and work is not just talk. By driving down VOC emissions, our products exceed the strictest industry standards for air quality by so much, we've had to set our own standards.



ULTRA-LOW VOCS

With 90% of time spent indoors, clear air matters. iD Click Ultimate showcases ultra low VOC emissions, less than 10 µg / m³.*

**TVOC after 28 days.*



PHTHALATE-FREE

Our iD Click Ultimate collection is phthalate-free. It contributes to healthier spaces and helps you reach green building certifications like BREEAM, WELL and LEED.



WATER-BASED INKS

At Tarkett, we use water-based printing inks with no organic solvents through all our printing processes. This contributes to iD Click Ultimate's ultra low VOC emissions. We are the only flooring manufacturer to use water-based inks with our digital printer.

Good materials. More proof.

At Tarkett, we demand to know every detail about the materials we use. It's why we're obsessed with the health and sustainability standards of Cradle to Cradle®. Complete transparency from us, peace of mind for you.



RADICAL TRANSPARENCY

97% of our materials are independently assessed by EPEA. Unique in the market, our MHS (Material Health Statements) give you a clear view of the health profile of the materials used in our flooring. Our EPDs (Environmental Product Declarations) share information on the materials environmental impact.

Selection Guide

iD Click Ultimate offers you the opportunity to tailor your flooring to best meet your project's requirements. You can put together the best combination of design, wear layer and format.

30

Moderate traffic

55

High traffic

70

Very high traffic



Residential

- Wide range of designs and colours
- Good durability
- Cost effective
- Easy renovation
- Less subfloor preparation
- Direct use (no glue)

Hospitality Guestroom

- Wide range of designs and colours
- Good durability
- Cost effective
- Easy renovation
- Less subfloor preparation
- Direct use (no glue)

Hospitality Bathroom

- Wide range of designs and colours
- Almost no repetition
- Customisation service
- Ultimate durability and resistance
- Waterproof & watertight
- Easy renovation
- No subfloor preparation
- Direct use (no glue)

Hospitality Restaurant / Lobby

- Wide range of designs and colours
- Almost no repetition
- Customisation service
- Ultimate durability and resistance
- Easy renovation
- No subfloor preparation
- Direct use (no glue)

Store / shops

- Wide range of designs and colours
- Almost no repetition
- Customisation service
- Ultimate durability and resistance
- Easy renovation
- No subfloor preparation
- Direct use (no glue)

Workplace Open spaces / Public spaces

- Wide range of designs and colours
- Almost no repetition
- Customisation service
- Ultimate durability and resistance
- Easy renovation
- No subfloor preparation
- Direct use (no glue)

Formats & Customisation

With iD Click Ultimate enhanced modularity is made more accessible, the 5 standard formats* allow for agile transformation of space.

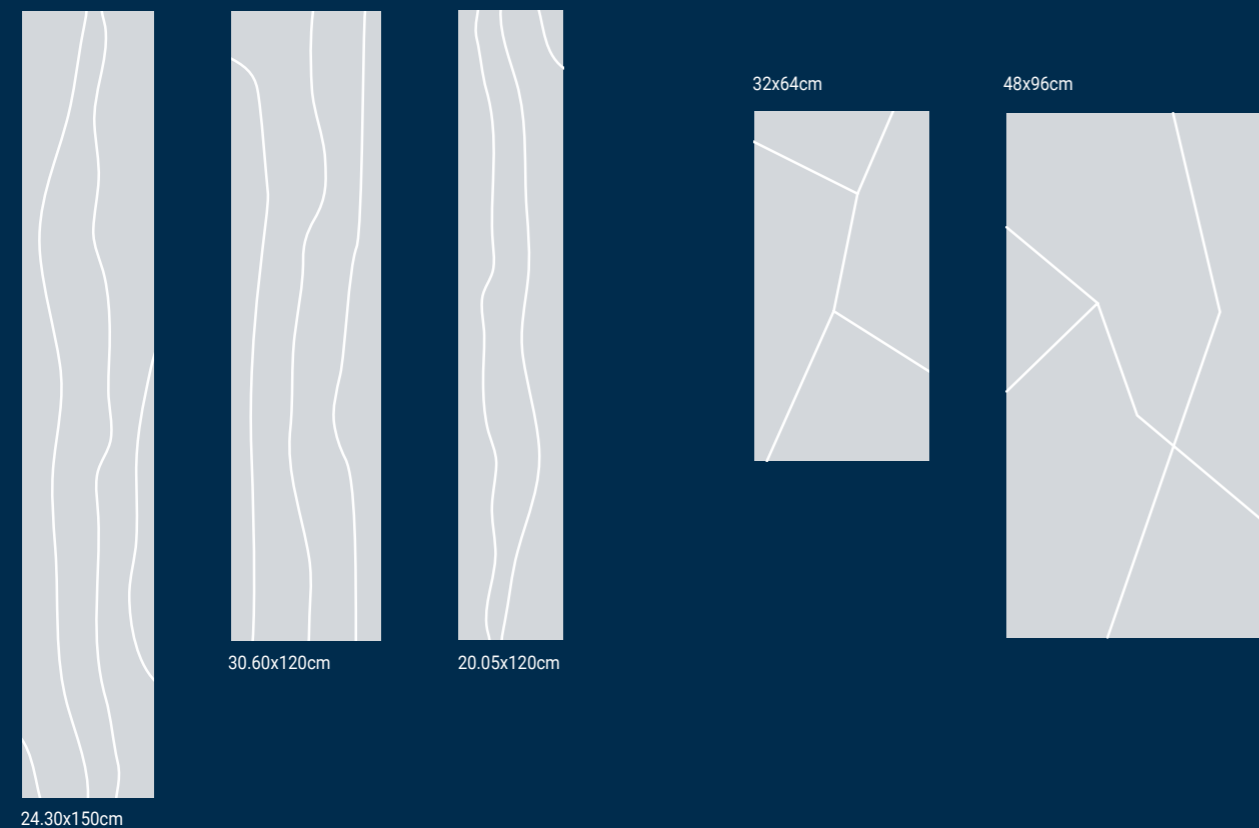

**Formats are specific per design. Please go to customisation if your chosen format is not available as standard.*

Through many customisable product features, iD Click Ultimate offers near endless combinations. Every aspect of the product is customisable with all decors.

PRE-DEFINED SERVICE

- Select an existing format
- Choose a bevel
- Select an embossing
- Select a colour from the library
- Pick a design from the library

A LA CARTE SERVICE

- Define a custom colour from NCS & RAL
- Request a new design



Select an existing format

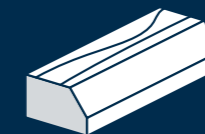

Choose a bevel



Select an embossing



Select a colour from the library



Pick a design from the library



Request a new design



Customised designs are available on MTO (make to order). Please check with your local sales representative for specific timing and customisation terms and conditions. All projects will have to be evaluated individually.

General Characteristics

98 Accessories

98 General

100 iD Click Ultimate

104 Project Specifications

106 Technical Datasheet

**108 Product details
& Skirtings**

Accessories

Skirting

DECORATIVE SET-ON SKIRTING

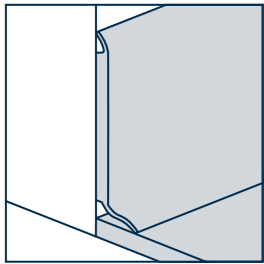

Compact PVC skirting with decorative film and PUR surface treatment to perfectly match selected designs.

Size (mm):
1950 length x 10 thickness x 60 height
1 box of 5 pieces (9.75lm)

For PVC skirtings matching the exact colour of our iD Click Ultimate designs, please have a look at page 109 of the brochure.

RENOVATION SKIRTING

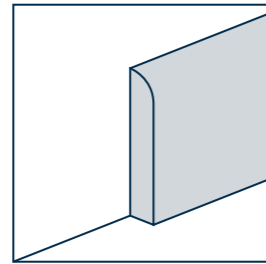

White high density polystyrene foam, 100% recyclable with a protective varnish.

Size (mm):
2000 length x 22 width x 110 height
1 box of 18 pieces (36lm)

White - 1411 301

General

Underlay

TARKOPROTECT 180

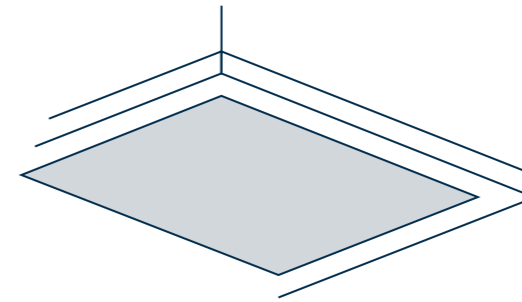

Self adhesive overlayer made of polyester veil for floor protection.

Size (m):
50 length x 1 width - 24 rolls per pallet.

White - 24990 000

Accessories

Accessibility

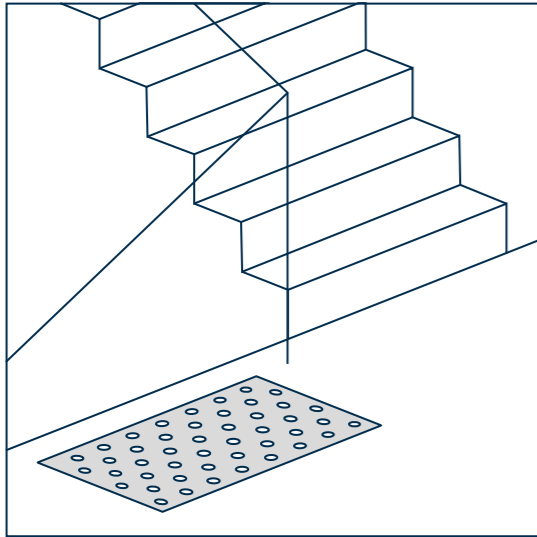

WARNING TILES SELF-ADHESIVE RECTANGULAR TILE

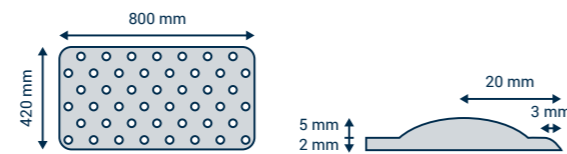

Rubber tile with studs that acts as a tactile warning for visually impaired people to alert them to a potential danger in staircases.

Size (mm):
420 width x 7.0 thickness x 800 length
1 box of 6 tiles

White - 1440 350
Grey - 1440 351
Black - 1440 352

iD Click Ultimate

WARNING TILES SELF-ADHESIVE SQUARE TILE

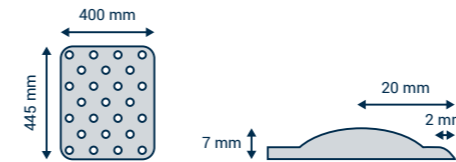

Polyurethane self-adhesive tile with studs that acts as a tactile warning for visually impaired people to alert them to a potential danger in staircases.

Size (mm):
400 width x 7.0 thickness x 445 length
1 box of 10 tiles

White - 1440 450
Grey - 1440 451
Black - 1440 452

Accessories

Skirting

LVT SKIRTING CAP*

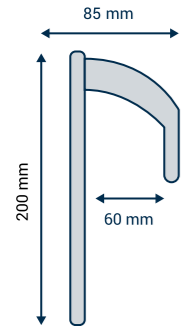

Aluminium skirting cap to be combined with skirting bottom in order to use floor covering on the wall as skirting. To be glued.

Size (mm):
2500 length x 6 width inside x 8.5 width outside x 20 height
10 units of 2.5 lm in a cardboard box = 25 lm

Silver - 26626 011
Stainless Steel - 26626 012

Stair Nosings

STAIRNOSE VERY HIGH*

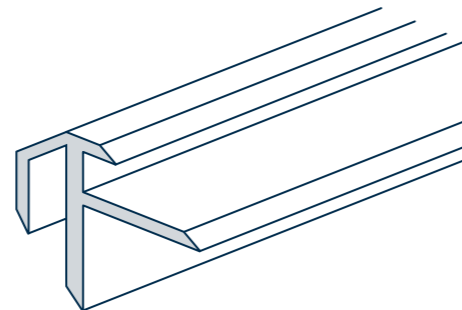

Aluminium stairnose used in high-traffic areas. To be screwed. Very resistant to very high traffic. Ribbed surface for slip-resistance.

Size (mm):
30 height x 38 width x 5/5.5 thickness x 2500 length
Full kit including stairnose profiles, screws and dowls.
5 units of 2.5 lm per box = 12.5 lm

Silver - 26626 011
Stainless Steel - 26626 012

iD Click Ultimate

Profiles

TRANSITION PROFILE GENERAL TRAFFIC*

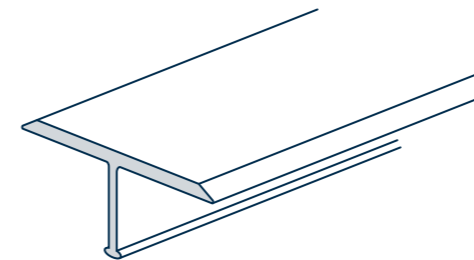

Aluminium transition strip for use in general traffic areas. To be screwed.

Size (mm):
2700 length x 24 width x 6 height.
10 units of 2.7 lm per box

Silver - 1451 021
Stainless Steel - 1451 022

TRANSITION PROFILE VERY HIGH TRAFFIC**

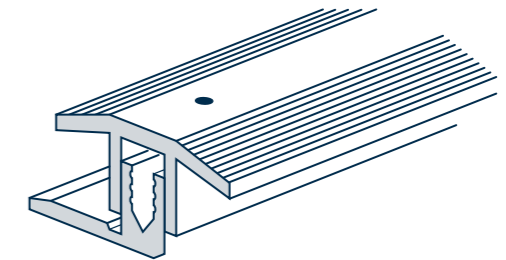

Aluminium transition strip in two parts for use in high-traffic areas. To be screwed.

Size (mm):
2700 length x 25 width x 4 height (down position)
2700 length x 25 width x 9.5 height (upper position)
10 units of 2.7 lm per box

Silver - 1451 011
Stainless Steel - 1451 012

*For iD Click Ultimate 30
**For iD Click Ultimate 30, 50-70

Project Specifications

iD Click Ultimate 55-70 Luxury Vinyl Tiles

Composition:

- Rigid Composite Core with triple-layer SPC manufactured through co-extrusion process with a density of 2,100 kg/m³
- Integrated acoustic backing of 19dB
- TEKTANIUM™ ultra matt finish and unequalled resistance PU coating
- GenClick® locking system
- Spaces of 12m² without repetition with digital printing technology (Naturals), Embossing in Register (Authentics) and Roto designs (Classics)

Dimensions:

- Planks: 20.05x120cm, 24.30x150cm, 30.60x120cm
- Tiles: 48x96 cm, 32x64 cm
- 6.5mm total thickness, wear layer of 0.70mm and Class 34 (iD Click Ultimate 70), 0.55mm and Class 33 (iD Click Ultimate 55).
Weight 10.70kg/m², 10.80kg/m² and 8.90kg/m²

Performance:

- Dimensional stability: ≤ |0.10|% per EN ISO 23999
- Heavy load capacity: up to 800 kg (iD Click Ultimate 70) or 500 kg (iD Click Ultimate 55)
- Residual indentation: ≤ 0.05 mm per EN ISO 24343-1
- Fire reaction class Bfl S1 per EN-ISO 13501-1
- Slip resistance R10 per DIN 51130
- Temperature resistance on the floor: 10°C to 60°C
- Excellence resistance to chemicals per EN ISO 26987, stains per ISO 26987 and wear ISO 16094
- Can be installed on almost all surfaces up to 20x20lm without joints, including ceramic tiles with joints of 8x3mm
- Watertight and waterproof
- Suitable for underfloor heating

Sustainability:

- 100% Circular through Tarkett Restart® program
- Platinum VOC emission: <10 µg/m³ (COV after 28 days)
- 20% recycled content according to ISO 14021
- 12.26 kg CO₂eq/m² Carbon Footprint (Cradle-to-Gate, EPD Modules A1-A3)
- 6.41 kg CO₂eq/m²/year Total Carbon Footprint (EPD Modules A-D)
- Environmental Product Declaration with recycled scenario and Material Health Statement available third party certified
- Floorscore certified, TEKTANIUM™ protection against stains and chemicals, superior cleanability and maintain. Phthalates and biocides-free
- 10 years commercial warranty, 20 years residential warranty

iD Click Ultimate

Sustainability credentials

GOOD MATERIALS

Made in Europe, the product is manufactured with a phthalate-free plasticiser.

RECYCLED CONTENT

The core layer is partially made of recycled vinyl. It contains on average 20% of recycled content according to ISO 14021.

RECYCLABILITY

The product is recyclable. Installation off-cuts and post-use flooring can be collected through the Tarkett ReStart® programme. The collected waste is recycled and used to reproduce high quality products comparable to the originals.

OPTIMAL INDOOR AIR QUALITY

Its emission rate of volatile organic compounds in air is less than 10µg/m³, tested 28 days after installation. A threshold 100 times lower than levels set by the most stringent EU regulations.

MATERIAL TRANSPARENCY

The selected flooring is covered by a specific third-party verified Environmental Product Declaration (EPD), disclosing several indicators linked to the product's environmental impact. The selected flooring is also covered by a third-party verified ingredient disclosure and material risk declaration down to 0.01%, ensuring compliance far beyond REACH regulation requirements, this Material Health Statement (MHS) is delivered by the Environmental Protection Encouragement Agency (EPEA).

Technical Datasheet

iD Click Ultimate

TECHNICAL DATA	STANDARD	iD CLICK ULTIMATE 70	iD CLICK ULTIMATE 55	iD CLICK ULTIMATE 30
Classification	Norm	Tarkett value	Tarkett value	Tarkett value
Product type	EN ISO 10582	Heterogeneous poly(vinyl chloride) floor coverings	Heterogeneous poly(vinyl chloride) floor coverings	Heterogeneous poly(vinyl chloride) floor coverings
Domestic classification	EN ISO 10874	23 Heavy	23 Heavy	23 Heavy
Commercial classification	EN ISO 10874	34 Very Heavy	33 Heavy	31 Moderate
Technical Characteristics	Norm	Tarkett value	Tarkett value	Tarkett value
Total thickness	EN ISO 24346	6.50 mm	6.50 mm	5.50 mm
Wear layer thickness	EN ISO 24340	0.70 mm	0.55 mm	0.30 mm
Total weight	EN ISO 23997	10 600 g/m ²	10 700 g/m ²	8 900 g/m ²
Binder content	EN ISO 10582	Type I	Type I	Type I
Surface treatment		Tektanium™	Tektanium™	Tektanium™
Digital Printing		Yes	Yes	No
Embossing in Register		Yes	Yes	Yes
Bevelled edges		4 sides mini bevels	4 sides mini bevels	4 sides micro bevels
Installation method		Click	Click	Click
Performance for CE Marking	Norm	Tarkett value	Tarkett value	Tarkett value
Declaration of Performance	EN 14041	0197-0058-DoP-2022-11	0197-0057-DoP-2022-11	0197-0056-DoP-2022-11
Technical Performance	Norm	Tarkett value	Tarkett value	Tarkett value
Dimensional stability	EN ISO 23999	Average measured value: ≤ 0.10 % Required value: ≤ 0.15 %	Average measured value: ≤ 0.10 % Required value: ≤ 0.15 %	Average measured value: ≤ 0.10 % Required value: ≤ 0.15 %
Curl resultant to heat	EN ISO 23999	≤ 1 mm	≤ 1 mm	≤ 1 mm
Reaction to fire	EN 13501-1	Bfl-s1	Bfl-s1	Bfl-s1
Residual indentation	EN ISO 24343-1	Average measured value: 0.02 mm Required value: ≤ 0.10 mm	Average measured value: 0.02 mm Required value: ≤ 0.10 mm	Average measured value: 0.02 mm Required value: ≤ 0.10 mm
Furniture leg	EN ISO 16581	No damage	No damage	No damage
Castor chair	EN ISO 4918	No damage	No damage	No damage
Impact sound reduction - ΔLw	EN ISO 717-2	19 dB	19 dB	19 dB
Reduction of in-room impact noise	NF S31-074	Class C (< 85 dB)	Class C (< 85 dB)	Class C (< 85 dB)
Thermal resistance	EN ISO 10456	0.07 m ² ·K/W	0.07 m ² ·K/W	0.06 m ² ·K/W
Colour fastness to light	EN ISO 105-B02	≥ 6	≥ 6	≥ 6
Chemical resistance	EN ISO 26987	Good resistance	Good resistance	Good resistance
Slip resistance	DIN 51130	R10	R10	R10
	EN 13893	Class DS (μ ≥ 0.30)	Class DS (μ ≥ 0.30)	Class DS (μ ≥ 0.30)
Peeling Resistance	EN ISO 24345	≥ 50N/50mm	≥ 50N/50mm	≥ 50N/50mm
Underfloor heating		Suitable (maximum 27°C)	Suitable (maximum 27°C)	Suitable (maximum 27°C)
Sustainability Performance	Norm	Tarkett value	Tarkett value	Tarkett value
Recyclability through ReStart®		Recyclable	Recyclable	Recyclable
Recycled content	ISO 14021	20%	20%	20%
Carbon Footprint (Cradle-to-Gate, EPD Modules A1-A3)		12.26 kg CO ₂ eq /m ²	12.26 kg CO ₂ eq /m ²	10.9 kg CO ₂ eq /m ²
Total Carbon Footprint (EPD Modules A-D)		6.41 kg CO ₂ eq /m ² /year	6.41 kg CO ₂ eq /m ² /year	5.58 kg CO ₂ eq /m ² /year
Total VOC Emissions	EN 16516	Platinum (≤ 10 μg/m ³)	Platinum (≤ 10 μg/m ³)	Platinum (≤ 10 μg/m ³)
Formaldehyde Emissions		≤ 10 μg/m ³	≤ 10 μg/m ³	≤ 10 μg/m ³
Dimensions and designs				
Plank (installed size)		1200 x 200.5 mm - 5 planks/box 1.2 m ² /box - 60 boxes/pallet 1500 x 243 mm - 3 planks/box 1.09 m ² /box - 69 boxes/pallet 1200 x 306 mm - 3 planks/box 1.10 m ² /box - 69 boxes/pallet	1200 x 200.5 mm - 5 planks/box 1.2 m ² /box - 60 boxes/pallet 1500 x 243 mm - 3 planks/box 1.09 m ² /box - 69 boxes/pallet 1200 x 306 mm - 3 planks/box 1.10 m ² /box - 69 boxes/pallet	1200 x 200.5 mm - 7 planks/box 1.68 m ² /box - 52 boxes/pallet -
Tile (installed size)		640 x 320 mm - 7 tiles/box 1.43 m ² /box - 52 boxes/pallet 960 x 480 mm - 3 tiles/box 1.38 m ² /box - 54 boxes/pallet	640 x 320 mm - 7 tiles/box 1.43 m ² /box - 52 boxes/pallet 960 x 480 mm - 3 tiles/box 1.38 m ² /box - 54 boxes/pallet	640 x 320 mm - 9 tiles/box 1.84 m ² /box - 48 boxes/pallet -
Number of designs available		43	43	22

The above information is subject to modification for the benefit of further improvement. (12/22).
According to the European Regulation N° 305/2011 for CE Marking, the Declarations of Performance are available on our website www.tarkett.com
Tarkett's instructions regarding installation, cleaning and maintenance should be observed. Please contact Tarkett at the address shown for these instructions.



Product details & Skirtings

iD Click Ultimate

DECOR	COLOUR	30 FORMAT	55/70 FORMAT	BEVELS*	0.30 SAP CODE	0.55 SAP CODE	0.70 SAP CODE	LRV%	SKIRTING
NATURALS - DIGITAL PRINTING									
Breccia	Grey		48x96cm	4V		260017004	260008004	36,05	26646052
Brushed Elm	Brown		30,6x120cm	4V		260020042	260011042	36,42	26646057
	Natural		30,6x120cm	4V		260020043	260011043	37,22	26646054
Chatillon Oak	Natural		24,3x150cm	4V		260023005	260014005	43,01	26646060
Creek Oak	Beige		20.5x120cm	4V		260016010	260007010	22,3	26646041
Forest Oak	Pistaccio shell		20.5x120cm	4V		260016020	260007020	46,37	26646030
	Nutmeg		20.5x120cm	4V		260016019	260007019	34,2	26646029
Nomad Oak	Linen		30,6x120cm	4V		260020024	260011024	41,58	26646069
Patina concrete	Dark grey		48x96cm	4V		260017025	260008025	17,3	26646034
	Light grey		48x96cm	4V		260017026	260008026	32,76	26646032
Sediment	Beige		48x96cm	4V		260017037	260008037	32,25	26646073
Variant Oak	Natural		20.5x120cm	4V		260016038	260007038	37,68	26646040
AUTHENTICS - EMBOSSED IN REGISTER									
Delicate Oak	Sugar		20.5x120cm	4V		260021013	260012013	51,05	26646096
	Clay	20.5x120cm	20.5x120cm	4V	260026012	260021012	260012012	25,66	26646095
	Toffee	20.5x120cm	20.5x120cm	4V	260026014	260021014	260012014	20,43	26646093
	Almond	20.5x120cm	20.5x120cm	4V	260026011	260021011	260012011	34,28	26646092
Highland Oak	Golden	20.5x120cm	20.5x120cm	4V	260026022	260021022	260012022	29,38	26646091
	Smoke	20.5x120cm	20.5x120cm	4V	260026023	260021023	260012023	25,98	26646089
	Arabica		20.5x120cm	4V		260021021	260012021	10,45	26646088
CLASSICS - ROTOGRAVURE									
Antik Oak	Natural		20.5x120cm	4V		260018003	260009003	28,17	26646008
	Beige	20.5x120cm	20.5x120cm	4V	260025001	260018001	260009001	32,26	26646007
	Dark grey	20.5x120cm	20.5x120cm	4V	260025002	260018002	260009002	25,48	26646006
Composite	Cool grey	32x64cm	48x96cm	4V	260024006	260019006	260010006	29,57	26646014
Contemporary Oak	Grey	20.5x120cm	24,3x150cm	4V	260025008	260022008	260013008	29,09	26646022
	Grege		24,3x150cm	4V		260022007	260013007	30,47	26646021
	Natural	20.5x120cm	24,3x150cm	4V	260025009	260022009	260013009	29,65	26646020
English Oak	Grege	20.5x120cm	24,3x150cm	4V	260025017	260022017	260013017	33,09	26646013
	Grey beige		24,3x150cm	4V		260022041	260013041	34,81	26646012
	Natural	20.5x120cm	24,3x150cm	4V	260025018	260022018	260013018	23,38	26646011
	Brown		24,3x150cm	4V		260022015	260013015	18,07	26646010
	Classical	20.5x120cm	24,3x150cm	4V	260025016	260022016	260013016	26,43	26646009
Rock	Grey	32x64cm	32x64cm	4V	260024030	260015030	260006030	34,9	26646001
Rustic Oak	Warm natural		20.5x120cm	4V		260018033	260009033	27,52	26646028
	Light grey		20.5x120cm	4V		260018032	260009032	46,56	26646027
	Beige	20.5x120cm	20.5x120cm	4V	260025031	260018031	260009031	31,64	26646026
Scandinavian Oak	Medium beige		20.5x120cm	4V		260018035	260009035	41,36	26646017
	Dark grey	20.5x120cm	20.5x120cm	4V	260025034	260018034	260009034	24,46	26646016
	Medium grey	20.5x120cm	20.5x120cm	4V	260025036	260018036	260009036	44,45	26646015
Vintage Zinc	Black	32x64cm	32x64cm	4V	260024039	260015039	260006039	8,33	26646003
	Silver	32x64cm	32x64cm	4V	260024040	260015040	260006040	19,02	26646002
Polished Concrete	Graphite	32x64cm	48x96cm	4V	260024027	260019027	260010027	32,64	26646177
	Indium	32x64cm	48x96cm	4V	260024028	260019028	260010028	25,07	26646175
	Steel	32x64cm	48x96cm	4V	260024029	260019029	260010029	6,95	26646176

*Micro bevels in iD Click Ultimate 30

About Tarkett

With a history of 140 years, Tarkett is a worldwide leader in innovative and sustainable flooring and sports surface solutions, with net sales of € 2.8 billion in 2021. Offering a wide range of products including vinyl, linoleum, rubber, carpet, wood, laminate, artificial turf and athletics tracks, the Group serves customers in over 100 countries across the globe. Tarkett has 12,000 employees and 34 industrial sites, and sells 1.3 million square meters of flooring every day, for hospitals, schools, housing, hotels, offices, stores and sports fields. Tarkett is committed to building “The Way to Better Floors” with circular economy and to reducing its carbon footprint. The Group has implemented an eco-innovation strategy based on Cradle to Cradle® principles, fully aligned with its Tarkett Human-Conscious Design® approach. Tarkett is listed on the Euronext regulated market (compartment B, ISIN: FR0004188670, ticker: TKTT).

www.tarkett-group.com

The designs and photos used in this brochure are for illustration purposes only. They are not contractual images and do not stand for product or installation recommendation.



■ **WESTERN EUROPE:** Austria: Tarkett Holding GmbH, Niederlassung Wien - Tel. +43 1 47 88 062 ■ Belgium: Tarkett Belux Sprl - Tel. +32 52 26 24 11 ■ Denmark: Tarkett A/S - Tel. +45 43 90 60 11 ■ Finland: Tarkett Oy - Tel. +358 9 4257 9000 ■ France: Tarkett SAS - Tel. +33 1 41 20 42 49 ■ Germany: Tarkett Holding GmbH - Tel. +49 621 68172 300 ■ Greece: Tarkett Monoprosopi Ltd - Tel. +30 210 6745 340 ■ Italy: Tarkett S.p.A. - Tel. +39 0744 7551 ■ Luxembourg: Tarkett GDL SA - Tel. +352 949 211 8804 ■ Netherlands: Tarkett BV - Tel. +31 416 685 491 ■ Norway: Tarkett AS - Tel. +47 32 20 92 00 ■ Portugal: Tarkett SA - Tel. +351 21 427 64 20 ■ Spain: Tarkett Floors S.L. - Tel. +34 91 358 00 35 ■ Sweden: Tarkett Sverige AB - Tel. +46 771 25 19 00 ■ Switzerland: Tarkett Holding GmbH - Tel. +41 043 233 79 24 ■ Turkey: Tarkett Aspen - Tel. +90 212 213 65 80 ■ United Kingdom: Tarkett Ltd - Tel. +44 (0) 1622 854 040 ■ **EASTERN EUROPE:** Baltic Countries: Tarkett Baltics: Tel. +370 37 262 220 ■ Czech Republic: Tarkett org. složka - Tel. +420 271 001 600 ■ Hungary: Tarkett Polska SP Z.O.O. magyarországi fióktelepe - Tel. +36 1 437 8150 ■ Poland: Tarkett Polska Sp. z o. o. - Tel. +48 22 16 09 231 ■ Russian Federation: ZAO Tarkett RUS - Tel. +7 495 775 3737 ■ Slovakia: Tarkett Polska, organizačná zložka - Tel. +421 2 48291 317 ■ South East Europe: Tarkett SEE - Tel. +381 21 7557 649 (44) 569 12 21 ■ Ukraine: Tarkett UA - Tel. +38 (0) 44 35 45 621 ■ **ASIA AND OCEANIA:** Australia: Tarkett Australia Pty Ltd - Tel. +61 2 88 53 12 00 ■ China: Tarkett Floor Covering (Shanghai) Co. Ltd. - Tel. +86 (21) 60 95 68 38 ext 841 ■ North East Asia: Tarkett Hong Kong Limited - Tel. +852 2511 8716 ■ India: Tarkett Flooring India Pvt. Ltd. - Bangalore - Tel. +91 80 4130 3793 - New Delhi - Tel. +91 11 4352 4073 - Mumbai - Tel. +91 22 2648 8750 ■ South East Asia: Tarkett Flooring Singapore Pte. Ltd. - Tel. +65 6346 1585 ■ **AFRICA:** Tarkett International: Tel. +33 1 41 20 41 01 ■ **MIDDLE EAST:** Tarkett Middle East: Tel. +961 1 51 3363/4 ■ Israel: Tarkett International: Tel. +33 1 41 20 41 01 ■ **NORTH AMERICA:** USA: Tarkett Inc. - Tel. +1 713 869 5811 / Johnsonite - Tel. +1 440 543 8916 ■ Canada: Tarkett Inc. - Tel. +1 450 293 173 ■ **LATIN AMERICA:** Brazil: Tarkett - Tel. 55 12 3954 7108 ■ Argentina - Chile - Uruguay: Tarkett Latam Mercosur - Tel. +54 11 47 08 07 72 / +54 9 11 44 46 88 82 ■ Bolivia - Colombia - Ecuador - Panama - Paraguay - Peru - Trinidad and Tobago - Venezuela: Tarkett - Tel. +55 11 9 8410 9310 / +55 11 95494 0069 ■ Mexico /Central America: Tarkett Latam Mexico - Tel. +55 11 98410 9310

The designs and photos used in this brochure are for illustration purposes only.
They are not contractual images and do not stand for product or installation recommendation.
Design: Supersky Studio / Images: Studio3D, Sweden

professionals.tarkett.com

