

INSTALLATION INSTRUCTIONS RESILIENT FLOORINGS

1 TRANSPORT & STORAGE

In general the rolls and boxes must be stored in a sheltered clean and dry indoor place and free from any pollution. Before installation, the rolls with 2m width should be stored upright and safely secured; other dimension above 2m should be stored horizontally. Tiles should be stored flat in their packages, in small neat p-iles (not more than 5 boxes high in the locality prior to installation).

They should also be protected from extreme temperature (heat and cold), moist, rust, rot, free from any contamination and not piled-up nor crushed under heavy weight. State of the art handling must be respected.

Rolls and tiles must be stored during 48 hours before starting the operation. For installation, room temperature should always be above 15°C or 18°C for linoleum. *Check the rules in your country; those temperatures could be different.*

Before installation, sheets and tiles should relax minimum 24h, out of packaging.

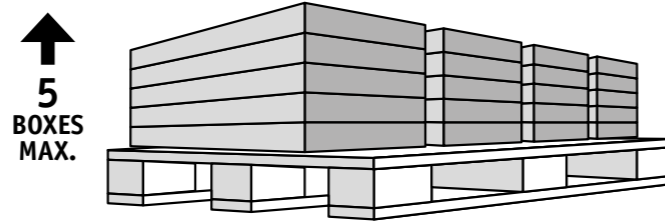

For modular products

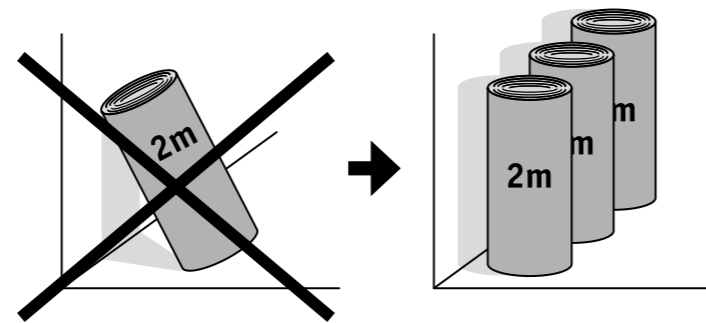

For 2m rolls: upright storage

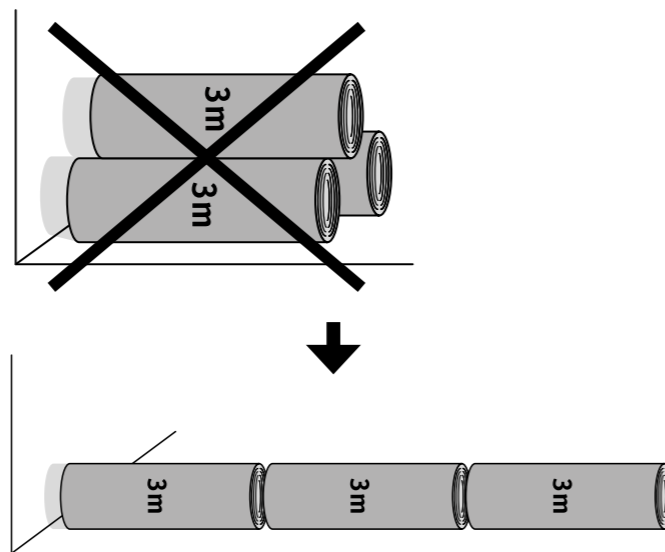

For ≥2m rolls: horizontal storage

2 HANDLING

For the best results, follow the installation instructions below, and use the tools and the accessories recommended by the manufacturer. Care should be taken when handling all types of floorcoverings to ensure that safety procedures are followed and damage does not occur to the material or people. Check the material for visible defects and/or damage before and during installation and report to Tarkett representative. For each continuous surface use the same batch number and install rolls/boxes in sequential order.

Trolley

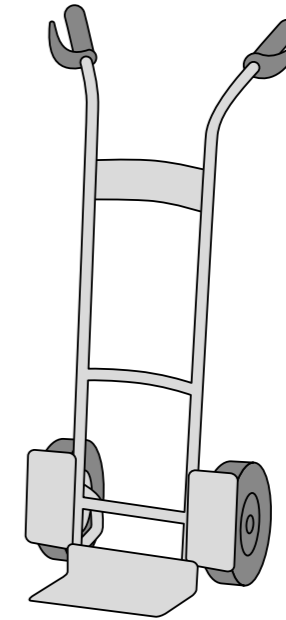

Roll carrying handles

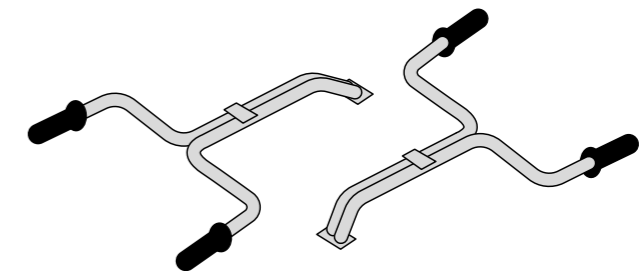

Rolling transporter

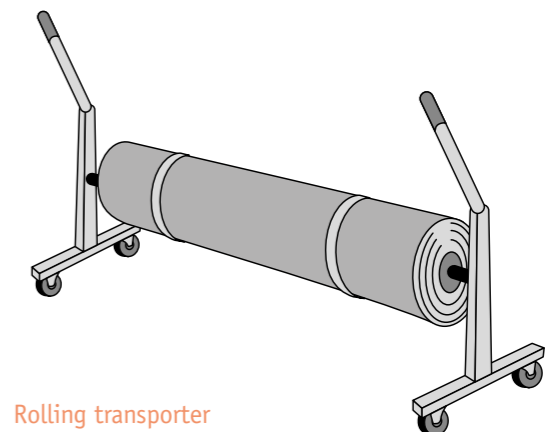

! Wrong transport, storage and/or handling could damage the flooring, causing aesthetical or technical issues. Tarkett does not warrant or guarantee flooring problems caused by inappropriate storage or handling.

INSTALLATION INSTRUCTIONS RESILIENT FLOORINGS

3 SUBFLOOR CONTROL

The subfloor quality is the 1st condition for a successful installation, so make sure it is in good condition to do a flooring installation.

Always bear in mind that in most countries, the installer is responsible for the acceptance of the subfloor on which he will do the installation. He will then be held responsible for any potential claim/litigation.

The subfloor must be flat, clean, free from all debris & residues, without any marks (no felt pen, marker of any type, ballpoint pens, paint, etc. that could cause discolouration due to migration) sound, dry, solid, hard, smooth.

The absorbency must be checked and subfloor should not be exposed to humidity. The preparation/dryness of the subfloor and installation procedures should all be as per the current relevant Standard within the country of use. The dryness of a solid subfloor should be below the maximum moisture level permitted when tested in accordance with the said Standard. Check the rules in your country to define the appropriate method and values.

For marking, only use a non-oily graphite pencil.

SUBFLOOR CHARACTERISTICS

HUMIDITY RATE

Always refer to each country regulations. For info, the drying time of a concrete floor is approx 2 weeks per cm. For testing, refer to the regulations valid in your country (Relative Humidity test, Calcium carbide system...).

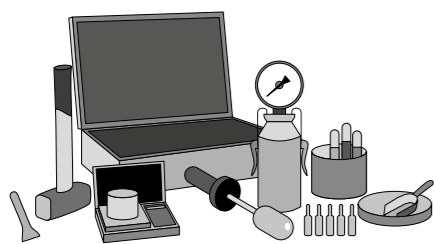

Calcium Chloride Moisture Test Kit

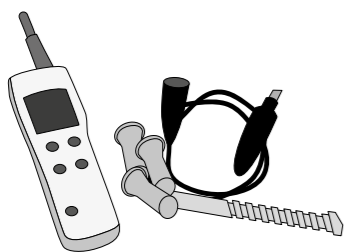

Concrete Moisture Meter

Excessive humidity rate can cause disbonding, bubbles, colour migration that Tarkett does not warrant or guarantee.

ABSORBENCY – POROSITY

Check local regulations, but in general a subfloor is said too absorbent when the absorbency time of a drop of water on concrete is less than one minute. In this case, a primer must be used before leveling compound, with a 1/1 dilution.

A subfloor is said non-absorbent when the absorbency time of a drop of water on concrete is more than 10/15 minutes. In this case, the primer should be used non-diluted.

Prior to the use of a primer, always follow manufacturer's instructions.

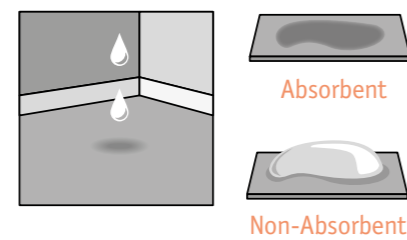

Non-absorbent subfloor could lead to a longer waiting time of the adhesive generating trouble in the bond plane. Too absorbent subfloor could lead to a shorter waiting time of the adhesive that could cause disbonding issue.

PLANARITY / FLATNESS

Different ways for measuring acc. countries.

France: tolerance must be less than 7mm over 2m for concrete subfloor and 5 mm for wood subfloor.

- UK/Nordic: 3mm over 2m (& depending on localities, SR1 or 2...).
- Germany: 4mm over 2m (Din 18202).
- NL/Australia: 2mm over 2m.

Tolerance must be less than 2mm over 20 cm of concrete/wood subfloor.

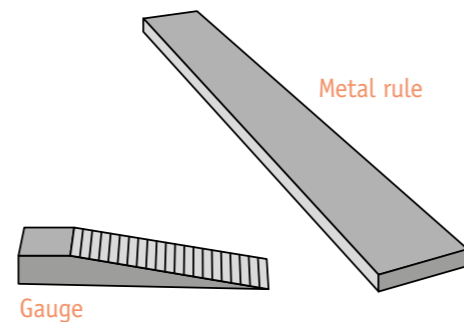

Non-flat surface could lead to visual issues or generate additional cost for the installer when using more levelling compound to recover the surface flatness.

CRACKS & JOINTS

First step will be to identify the type of crack or joint that will be discovered on the building site to adapt the treatment.

CRACKS

Cracks (0.3 to 1mm large) can appear during the drying of the concrete by contraction.

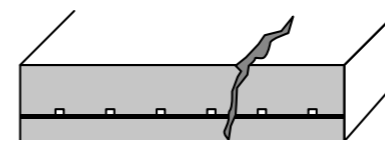

MICRO-CRACKS

Cracks almost not visible ($\leq 0,3$ mm large).

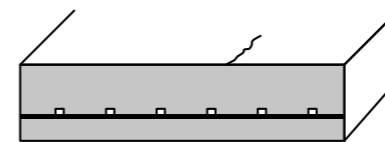

EXPANSION JOINTS

Expansion joints are used to compensate dimensional variations and building movements.

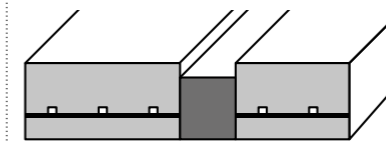

ISOLATING JOINTS

Isolating joints separate the screed from other independent building constructions (walls, pillar).

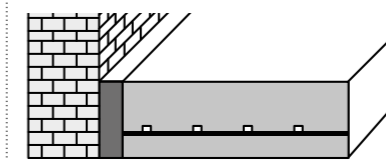

CONTRACTION (DIVIDING) JOINTS

Contraction joints allow free contraction of concrete and avoid cracks during drying.

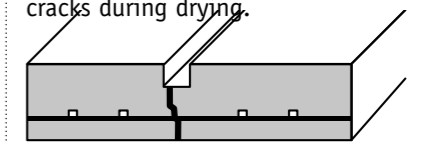

CONSTRUCTION JOINTS

Construction joints are used to stop daily pouring of concrete slab.

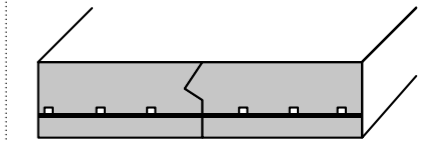

HARDNESS

The subfloor has to be resistant enough to compression and indentation.

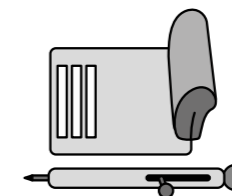

To measure the hardness of the concrete, installer can use a sclerometer.

Isolating joints separate the screed from other independent building constructions (walls, pillar).

When the subfloor is not hard enough, significant traffic or heavy load could damage screed/levelling compound and could cause visual/technical defects.

SOUND

The subfloor has to be free from contaminants such as hydrocarbon stains, paints, chemical residues or laitance on the surface.

Any contaminant left on the subfloor could cause colour migration and product damage.

CLEAN

The subfloor has to be free from any particles, dust, traces of felt pen or marker.

Particles, scratches and residues could cause visual defect (telegraphing effect).

INSTALLATION INSTRUCTIONS RESILIENT FLOORINGS

■ SUBFLOOR TYPES - PREPARATION

NEW SUBFLOOR

■ CONCRETE/CEMENT BASE

Preparation: water base primer compound + self levelling compound adapted to the traffic level.

■ WOOD OR WOOD PARTICLES/PLYWOOD BASE

Preparation: wood adapted primer compound recommended, direct installation possible or add a special wood fiber levelling compound.

For wood base, you should check:

- flexibility (thickness - length)
- fixing – cupping (opening)
- glued grooves and tongues
- caulking of joints (wood paste)
- sanding (smoothing).

■ BITUMEN BASE

Preparation: neoprene vinyl emulsified primer or bitumen adapted primary + bitumen adapted self levelling compound.

■ ANHYDRITE BASE (HUMIDITY RATE < 0.5% CM)

Preparation: sanding of the surface then apply an adapted primer or emulsion, in principle, screeding is not necessary.

■ METAL

Preparation: apply an anti-rust primer + gluing, after thorough cleaning of any oily residue.

OLD SUBFLOOR (RENOVATION)

■ TERRAZZO OR CERAMIC TILES

Preparation: 1st make sure that all tiles are still well bonded to subfloor. Removal of surface coating or sealer
- Apply an emulsified primer + adapted self levelling compound.

■ WOOD PARQUET (GLUED, NOT FLOATING)

Preparation: 1st check that all wood planks and pieces are well in place, solid and securely fixed, then apply a primer or adapted emulsion + fibre reinforced self levelling compound specific for wood.

NOT recommended for HOMOGENEOUS Vinyl Products.

OLD FLOORCOVERING

■ TEXTILE

Preparation: must be fully removed, scraped, and then apply a self levelling compound adapted to the area.

■ VINYL

Preparation: we recommend removing all old floorings (for security, fire regulations, migration prevention etc...), scraping and applying an emulsified primer + self levelling compound adapted to the area.

It may exceptionally be possible to install over old HO compact Vinyl floorings or even VCT type which are in good conditions & well bonded to the subfloor, and mainly applicable for small areas.

Two possibilities: thorough cleaning and degreasing of the surface & either install directly after application of an acrylic base adhesive adapted for PVC on PVC installation. Or, application of cement base levelling compound, according to manufacturer's recommendations.

If installing over old floorcovering, specific safety regulations have to be strictly followed. Please check with all local regulations. For heavy duty usage, old floorings must be removed.

UNDERFLOOR HEATING

Stop heating at least 48h before screeding and/or floorcovering installation.

Re-start heating progressively 48h after installation (few degrees per day).

In case of underfloor heating, we recommend that the vinyl tiles are hot welded.

The temperature should never exceed the floorcovering industry agreed maximum of 27°C.

Ensure that the room temperature will remain at minimum 18°C for installation.

■ MATERIALS FOR INSTALLATION

PRIMER

Different types:

solvent/water based, PU, Epoxy.

Main actions:

- grade the site & the overabsorbent and/or different subfloor surfaces.
- grade the permeability of subfloor where drying time could be too quick
- improve the bonding performance of the leveling compound on nonporous subfloor.

Application:

in general, the primer is applied with a brush/roller.

Consumption depends on the planarity of the subfloor:

80 - 120 g/m².

Strictly follow manufacturer's instruction.

Applying a leveling compound without using first a primer could cause delamination or cracks of the levelling compound.

ADHESIVE

Although Tarkett may recommend a selection of manufacturer adhesive, we do not however guarantee the products listed. The list of products and manufacturers are not guaranteed complete or current.

Tarkett would not accept any liability for any of these products failing to perform in conjunction with any of their products.

It is the responsibility of the adhesive manufacturer and flooring contractor to ensure the products being used are appropriate for use and applied in accordance with the manufacturer recommendations.

For best selection, always check:

- Compatibility with the flooring product backing (PVC, PU, jute...)
- Aspect of the backing: rough, smooth, fibers, grid...
- Flooring porosity (textile, jute...)
- Subfloor porosity (absorbent or not)
- Quality/Performance (polyvalence, consumption...).

■ IN GENERAL:

Moderately absorbent subflor: use finely notched trowel (approx. 250g/m² to 300g/m²).

- For compact products (smooth backink): use **A1** spatula (TKB model).
- For acoustic products (honey comb foam): use **A2** spatula (TKB model).

Non absorbent subflor: use very finely notched trowel (approx. 150g/m² to 200g/m²).

- May be the case for wall, Tarkolay, etc: use **A4** spatula (TKB model).

SELF-LEVELLING COMPOUND

Dfinition:

Is a smoothing cement based compound finish for indoor use that will be covered by a floorcovering.

Main actions:

- rectify the subfloor porosity = possibility to glue without any particular preparation
- self levelling action resulting in homogeneous & smooth surface
- allow regularity of glue layer and drying time on the whole surface.

Consumption (average):

1.5 Kg / 1 mm / m²

Heavy duty = 2-3 mm thickness (acc. country).

Strictly follow manufacturer's instructions.

Consider flooring nature, subfloor type and conditions of use to determine the adhesive type and the spatula. According manufacturer's instructions and building site conditions, determine the drying and working time.

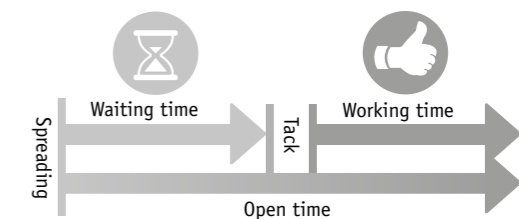

Waiting time = time needed till you are able to lay the floorcovering in the glue with correct bonding.
Working time = time for laying, heavy rolling and trimming of the floorcovering.

In general, the application of glue is made with a serrated spatula (TKB ref.: A1 for compact, A2 for acoustic, B1 for Linoleum...) or a roller (for special glue).

■ FOR LINOLEUM:

For Linoleum use a notched trowel, type will depend on the backing (approx. 300g/m² to 350g/m² for jute backing, 200g/m² to 300g/m² for foam backing).

- For compact products (jute backing): use **B1** spatula (TKB model).
- For acoustic products (honey comb foam): use **A2** spatula (TKB model).

Before laying down the floorcovering, in case application require a drying time of the adhesive, always check that water or solvents are evaporated (finger test - no transfer). Other application may require wet bonding (see Manufacturer instruction) like for linoleum or LVT.

Heavy roller must be used to ensure bonding.

For more details on adhesives, please refer to the specific Tarkett Adhesive recommendation list.
http://professionals.tarkett.com/sites/tarkettb2b_int/files/pdf/tarkett-floor-adhesive_recommendations.pdf

INSTALLATION INSTRUCTIONS RESILIENT FLOORINGS

4 ■ INSTALLATION

Please refer to each individual installation notice per product range, adhesive chart with Tarkett selection as guide line.

■ GENERAL RULES

1 ■ ROOM DIMENSIONS

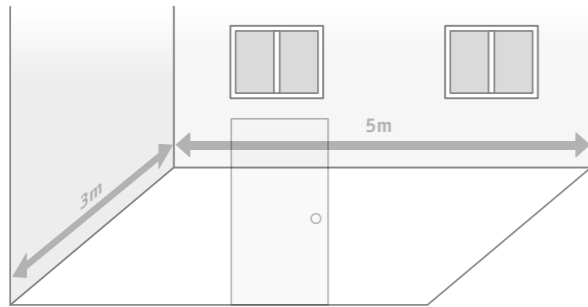

If the room is reasonably square, the sheets should run parallel to the incoming light. In long, narrow rooms it is best to install the sheets along the length of the room.

2 ■ LAYOUT NOT OK

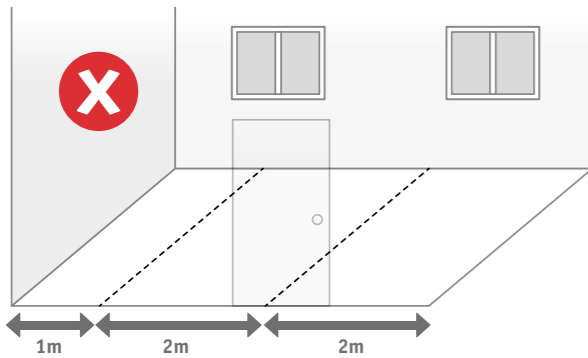

Joint placed at a door step.

3 ■ LAYOUT NOT OK

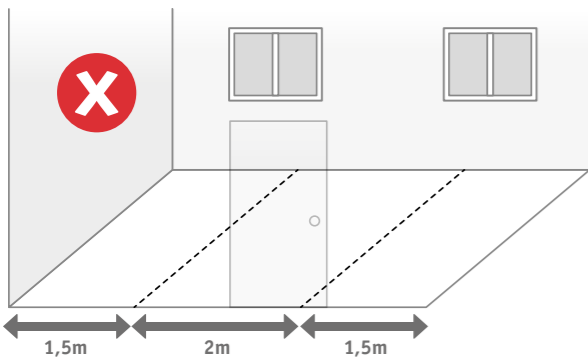

Loosing material.

4 ■ LAYOUT OK

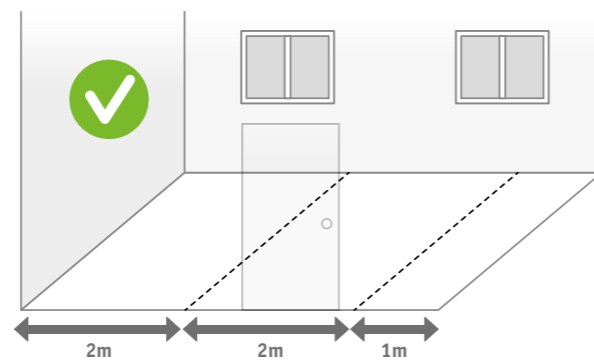

5 ■ REFERENCE LINE

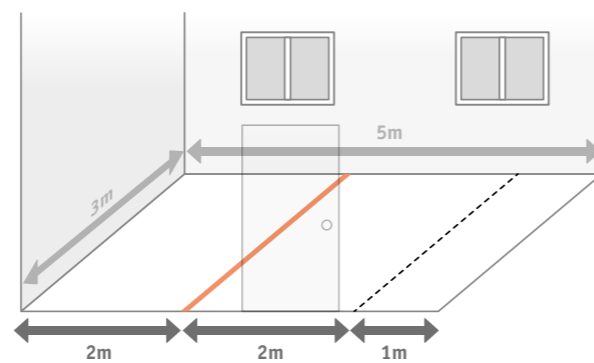

6 ■ SHEETS PREPARATION (CUTTING AND RELAXATION)

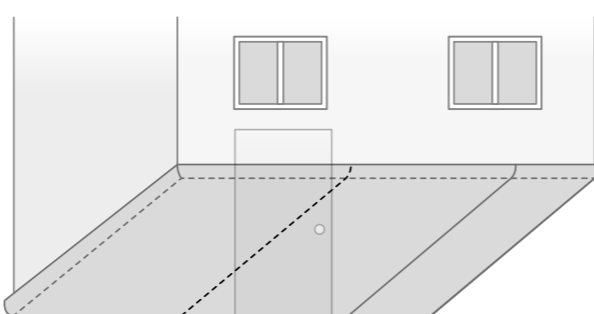

Align the sheet edge to the reference line.

Sections of flooring must be cut to the required lengths, plus an allowance of a few centimeters.

■ LAYING - SHEETS

7 ■ HALF FOLDING OR ROLLING

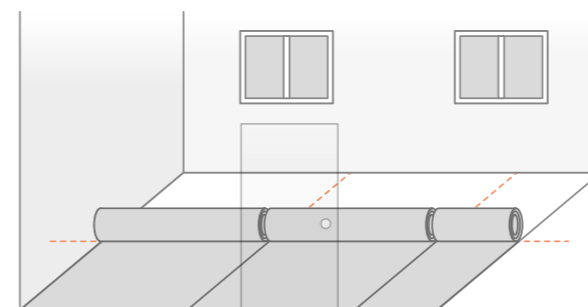

Can be rolled or fold.

8 ■ GLUING

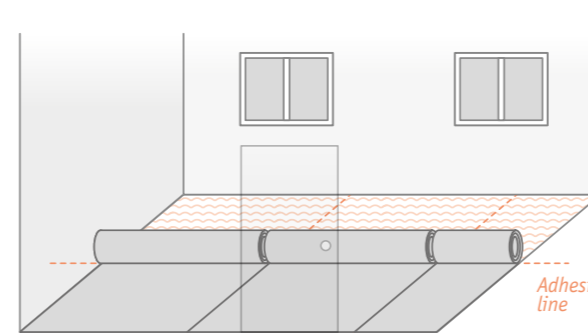

Spread the adhesive with the appropriate spatula.



Pay attention to spread adhesive till the line. For the second half, ensure not to let space without adhesive or to overglue.

9 ■ FIRST SHEET FOLDING BACK INTO THE ADHESIVE AND PRESSING

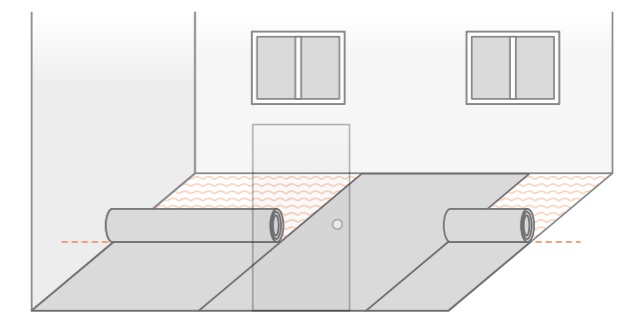

It's important to use the cork press when you gradually roll out the sheets onto the adhesive. In this way, you will avoid catching air under the sheets that may cause blisters later on.

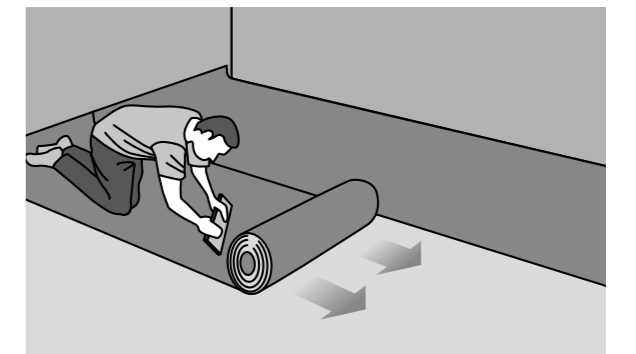

INSTALLATION INSTRUCTIONS RESILIENT FLOORINGS

Please refer to each individual installation notice per product range, adhesive chart with Tarkett selection as guide line.

■ LAYING - SHEETS

10 ■ NEXT SHEETS FOLDING BACK AND PRESSING

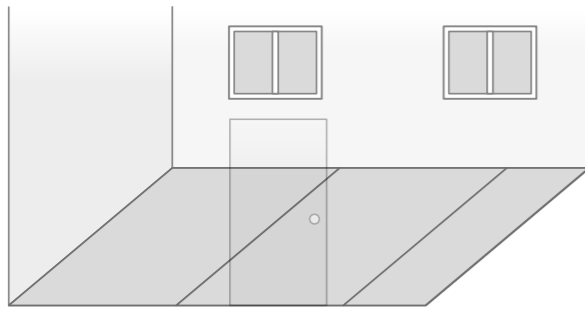

11 ■ REPEAT FOR THE SECOND HALF

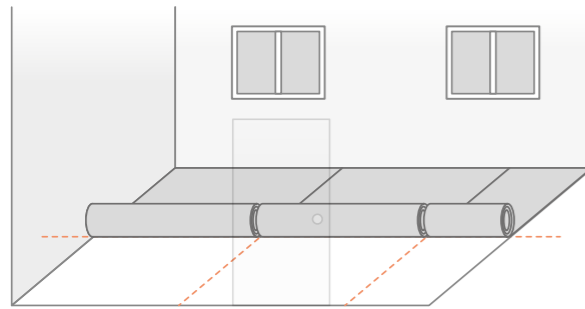

12 ■ GLUING

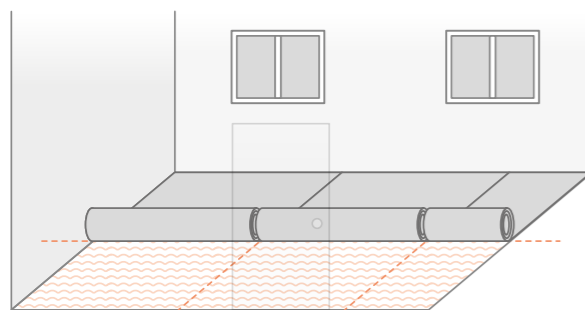

13 ■ FIRST SHEET FOLDING BACK INTO THE ADHESIVE AND PRESSING

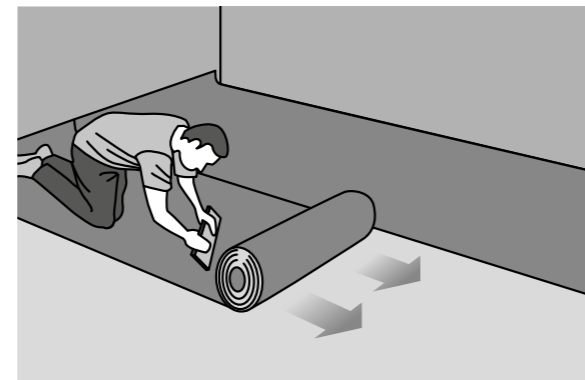
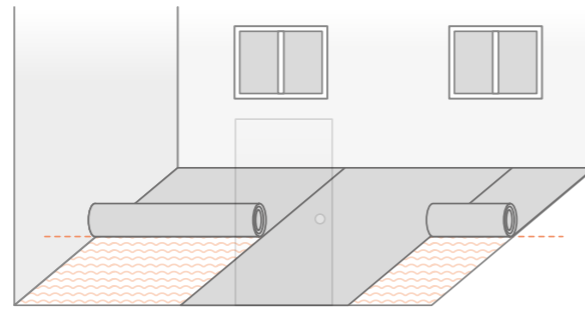

It's important to use the cork press when you gradually roll out the sheets onto the adhesive. In this way, you will avoid catching air under the sheets that may cause blisters later on.

14 ■ NEXT SHEETS FOLDING BACK

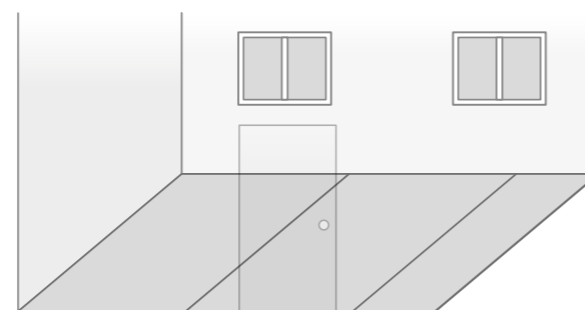

Repeat the same operation with the second half of sheets.

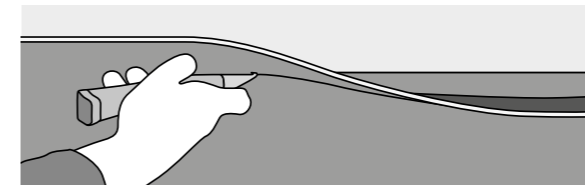

When gluing and pressing is done, excess of material close to walls and obstacles can be trimmed/flushed (freehand cut).

TOOLS FOR FREEHAND TRIMMING:

Knife:



Hook and concave blades:



15 ■ FINAL PRESSING

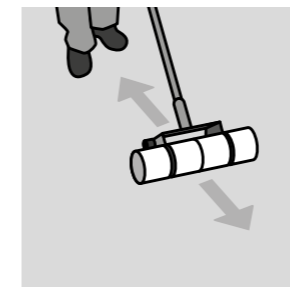
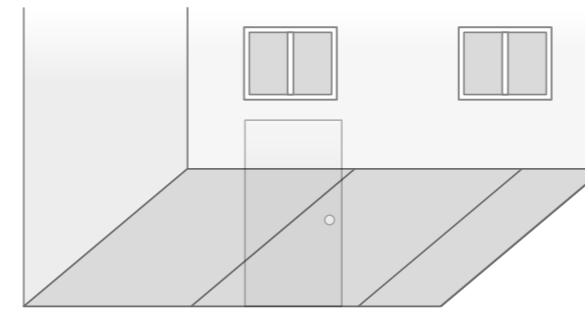

And then, use the heavy roller (mini 50kg) to ensure the final bonding.

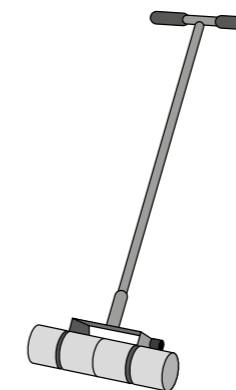

16 ■ HOT OR COLD WELDING

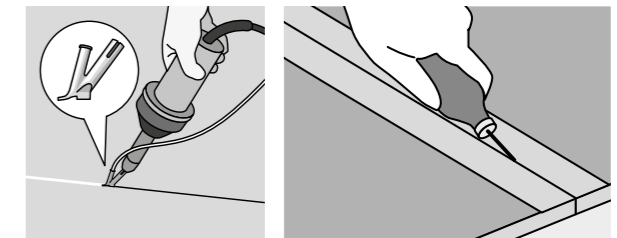
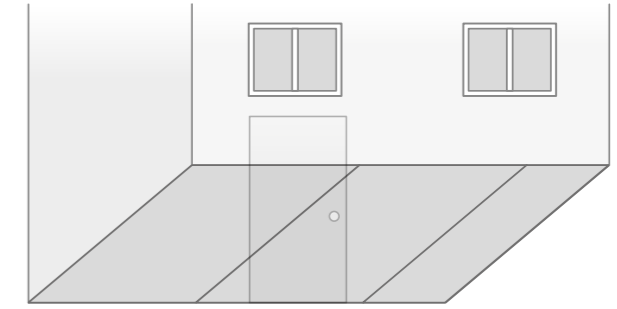

Specific case of Linoleum:

- Due to jute backing, linoleum will require wet bonding installation and due to its construction, installer will have to use scribing tools to trim edges and joints. For more details, please refer to the specific Linoleum installation instruction.

INSTALLATION INSTRUCTIONS RESILIENT FLOORINGS

Please refer to each individual installation notice per product range, adhesive chart with Tarkett selection as guide line.

■ LAYING - TILES

1 ■ ROOM DIMENSIONS

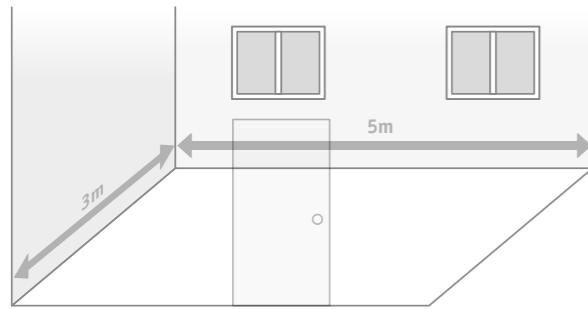

2 ■ LAYOUT

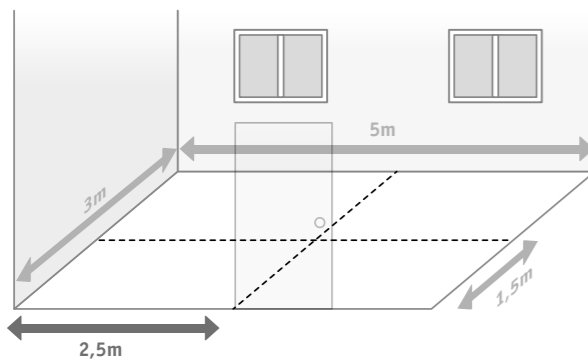

3 ■ REFERENCE AXES

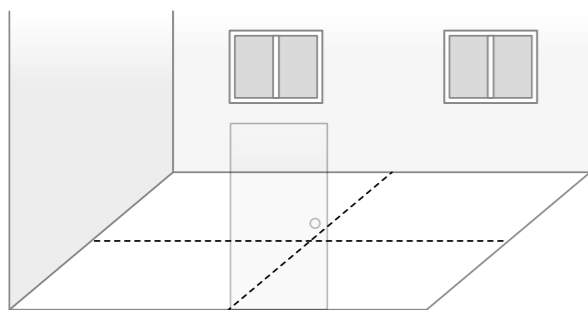

4 ■ STARTING LINES DEFINITION

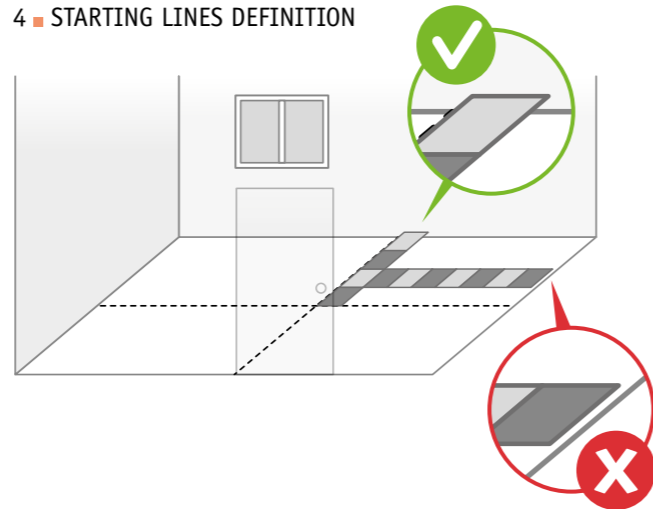

5 ■ REFERENCE LINE

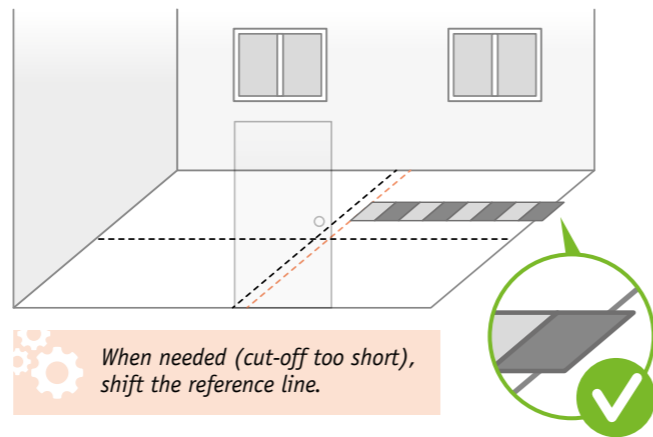

When needed (cut-off too short), shift the reference line.

6 ■ GLUING

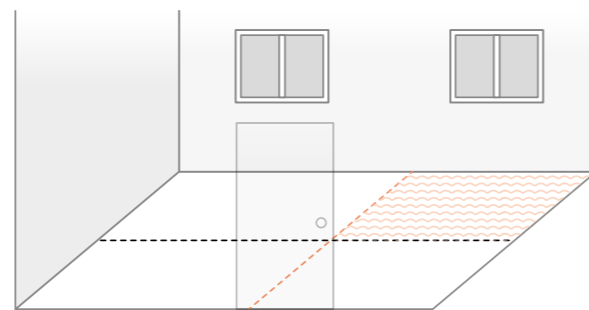

7 ■ PLACEMENT

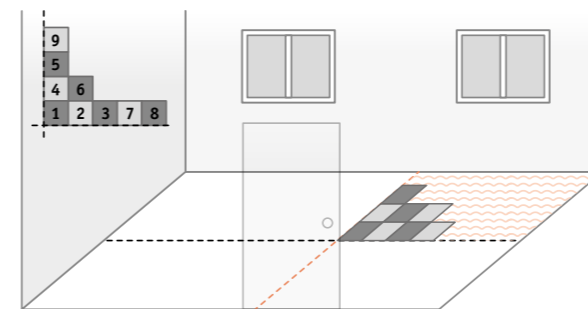

8 ■ SCRIBING

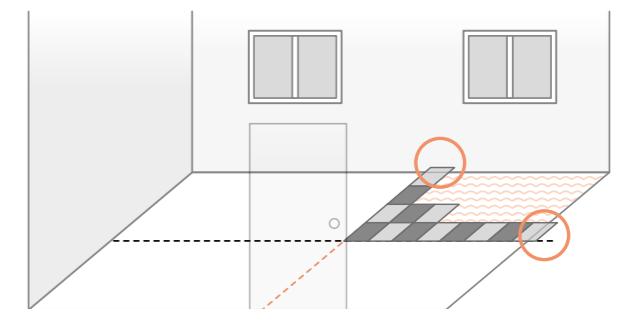

■ SCRIBING

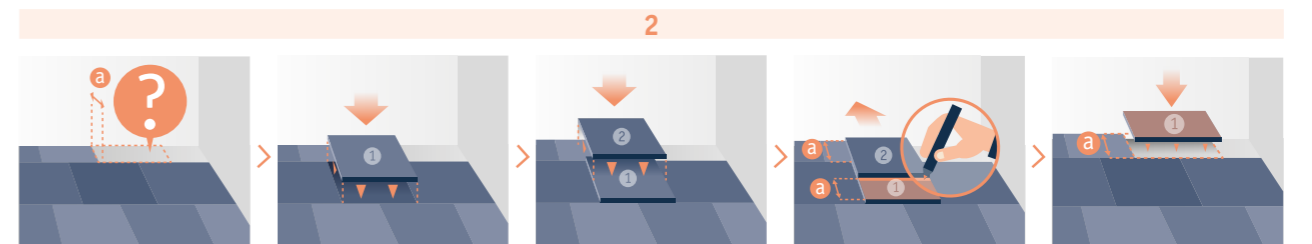
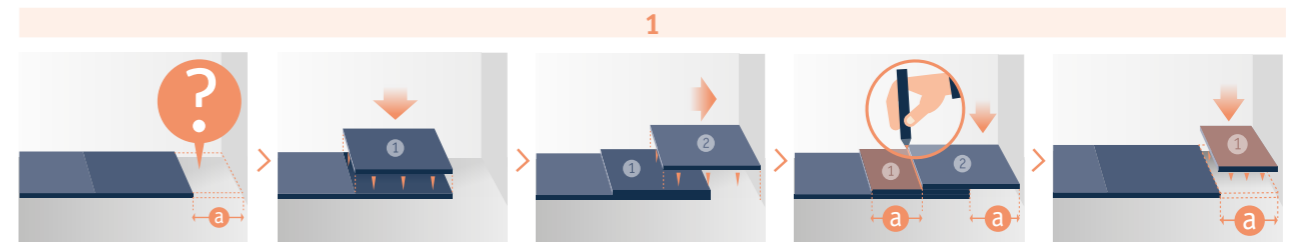
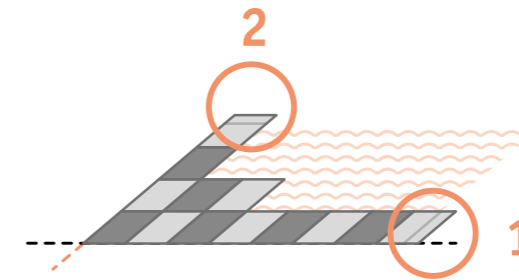

INSTALLATION INSTRUCTIONS RESILIENT FLOORINGS

Please refer to each individual installation notice per product range, adhesive chart with Tarkett selection as guide line.

■ LAYING - TILES / DIAGONAL INSTALLATION

■ SCRIBING

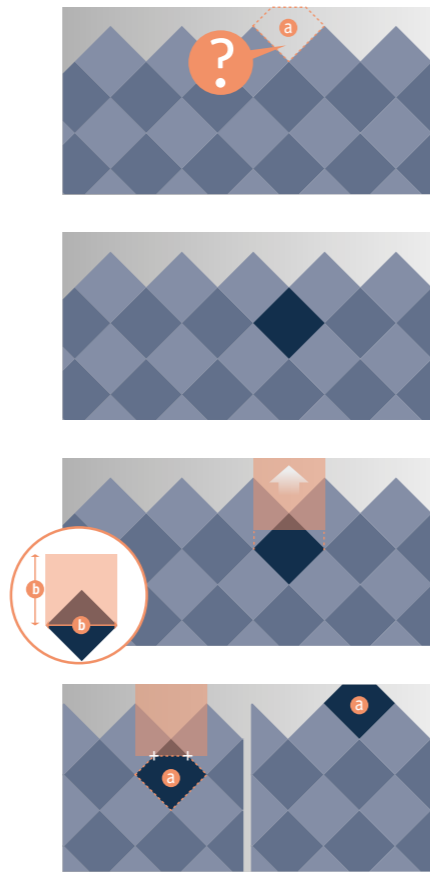
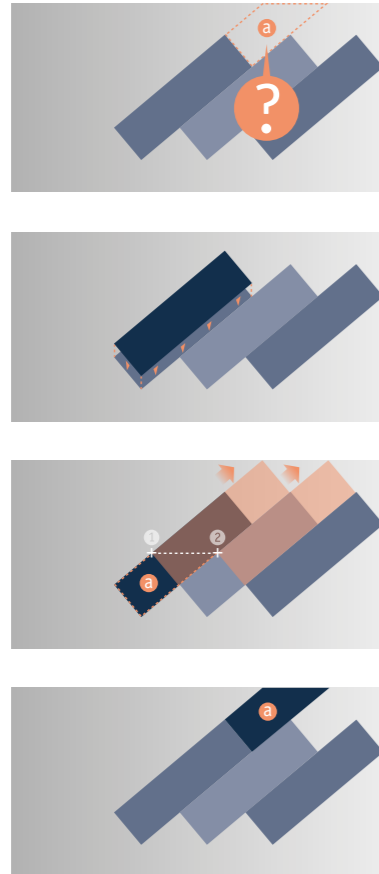

■ CONTINUE WITH THE OTHER QUARTERS

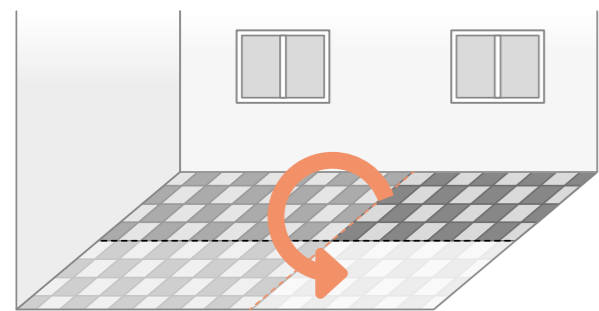

■ PRESSING OF THE WHOLE INSTALLATION

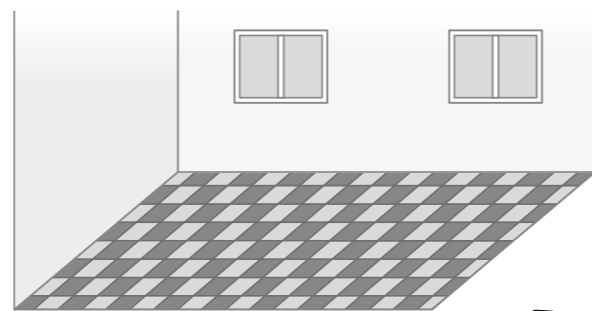

Repeat the same operation with the second half of sheets. And then, use the heavy roller (mini 50kg) to ensure the final bonding.

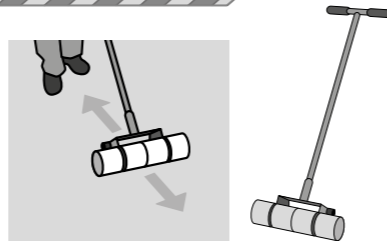

■ JOINTS WELDING

According to the product installed and the classification of the room, you could either hot weld (all types of flooring) or cold weld the joints (PVC HE only). Joints treatment depends on room classification; please refer to your country regulation to determine which type is accepted/required.

HOT WELDING (MIN. 24H AFTER INSTALLATION):

■ GROOVING

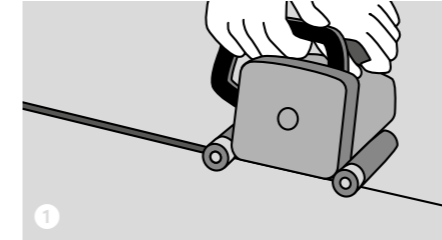

■ WELDING

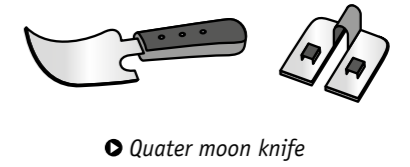
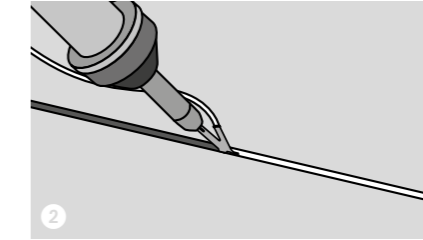

■ TRIMMING (X2)

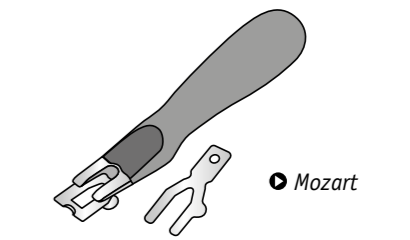
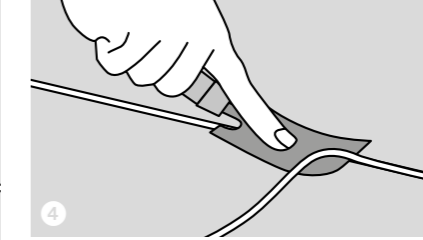
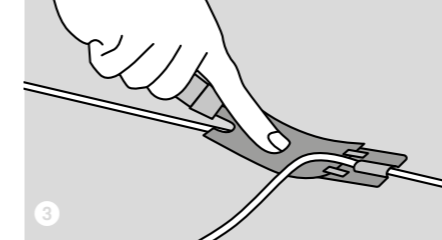

■ GROOVING MACHINE

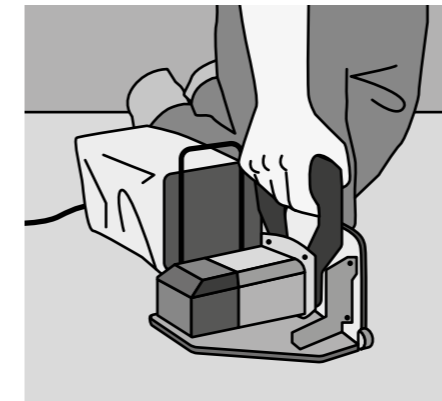

■ HOT AIR WELDING GUN + NOZZLE

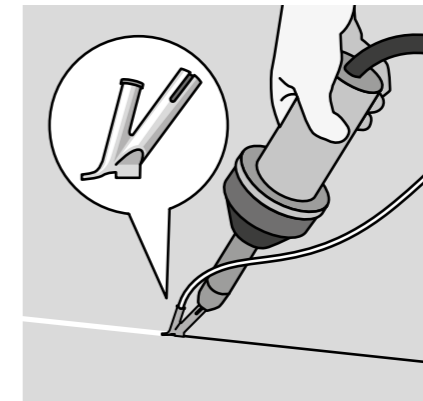

RECAP TABLE OF WELDING PARAMETERS

Flooring	Gap between product	Groove	Deepness	Nozzle	T°c	Speed	Trimming guide
Ho	Crédit Cart 0.8mm		2/3 of the thickness for compact, till foam for acoustic and till jute for linoleum but max. 2.5mm	Hot speed nozzle	350 - 400°C	± 2ml/min	0.5 for compact and 0.7 for acoustic
He	0						
Li	Crédit Cart 0.8mm			Open nozzle	500 - 550°C		Flooring

RESULTS OF WELDING AFTER TRINNING

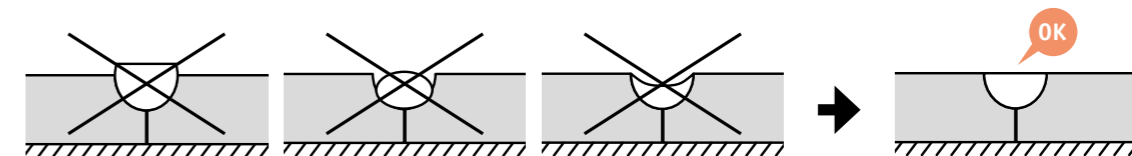

! Always adapt the t°C speed & pression to the situation.

INSTALLATION INSTRUCTIONS RESILIENT FLOORINGS

Please refer to each individual installation notice per product range, adhesive chart with Tarkett selection as guide line.

HOT WELDING (MIN. 24H AFTER INSTALLATION):

OVERLAP FLOORING AND CUT BOTH LAYERS

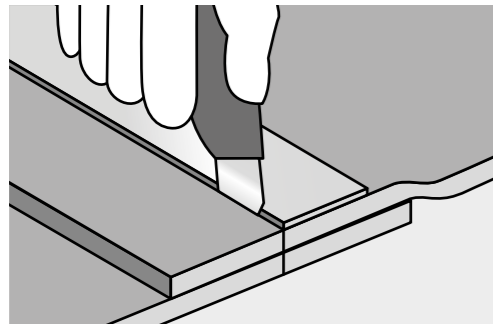

- Realization 24 hours after installation.
- Overlap the 2 sheets till the potential pattern match is achieved.
- The overlapping will be double cut in one step or 2 in case of thick flooring alongside a metal ruler.

Result should be an extremely tight joint.

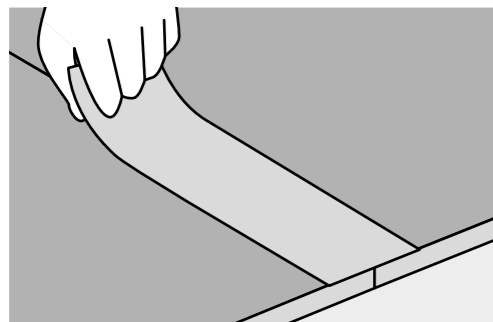

- Fix a special masking tape, centred over the cut seam, then cut the masking tape with the rolling knife within the seam.
- Apply the cold welding liquid by pressing the needle deeply into the seam.

Important: ensure you apply enough liquid along the entire joint.

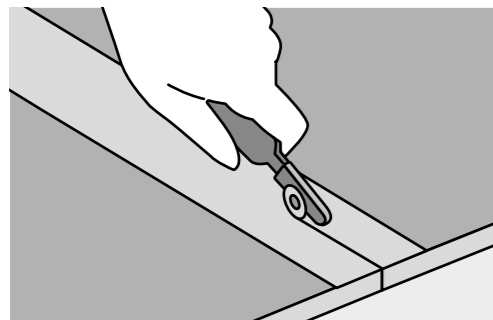

- After 10 minutes the cold-welding liquid on the masking tape should be dry and the tape is removed carefully backwards.

The seam can be walked on after 24h.

APPLY COLD WELDING SOLUTION

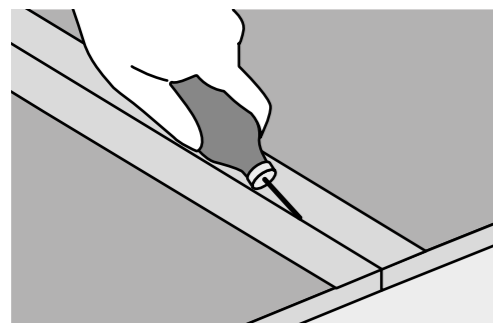

SPECIFIC PRODUCTS

For the following products: Linoleum, conductive floorcovering, stairs, wet room concept, please refer to specific installation instructions.

COVE FORMING

In particular cases (wet room concept, hospital...), cove forming could be mandatory.

WITH A COVE FORMER

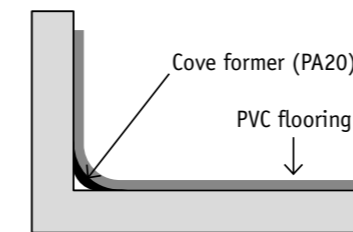

BY THERMOFORMING

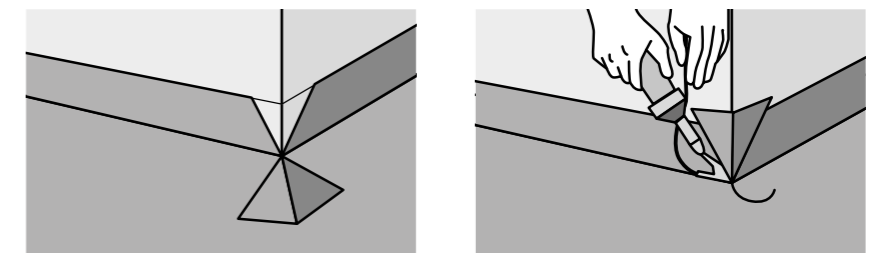
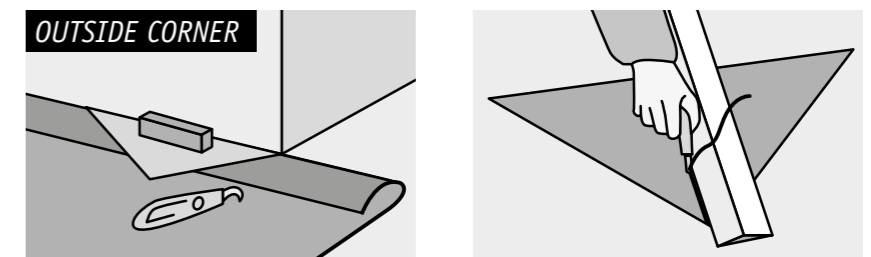
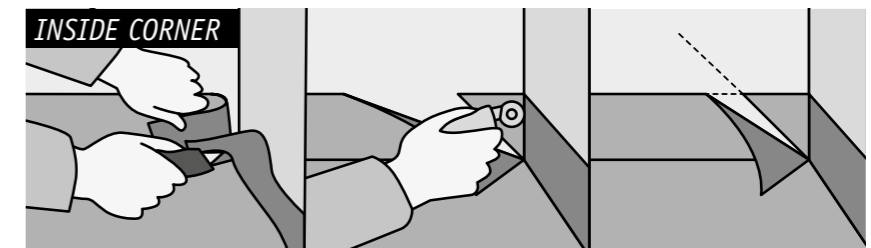
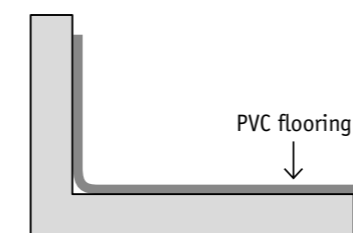

ACCESSORIES

Many accessories are available to complete the installation: stairs profiles and borders, warning strips and signage, wall profiles, skirting...

INSTALLATION INSTRUCTIONS RESILIENT FLOORINGS

5 INSPECTION

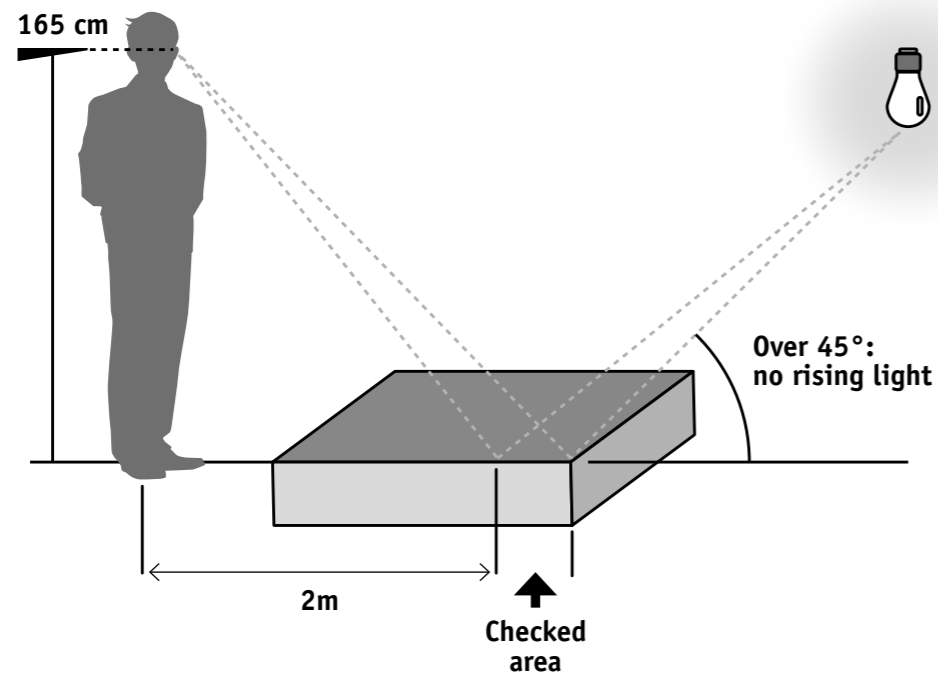

6 AFTER INSTALLATION

- Clean working area from all adhesive marks, stains and dust.
- Prevent soiling by protecting the area.
- Open the area to normal traffic 48 hours after installation and move furnitures after 72 hours.

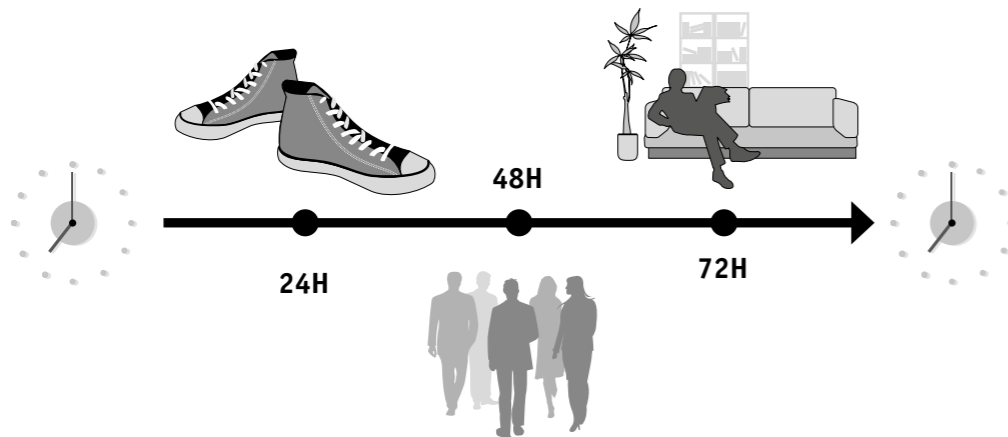

5 REMINDER

	Linoleum	PVC He	PVC Ho
Transport & Storage			
Transport & Downloading	Transport: - Truck: laying (3 rolls max) - Container: standing - Unloading: very carefully (role should not fall down)	Transport : - Truck : laying (3 rolls max) - Container : standing - Unloading : carefully	Transport : - Truck : Laying (3 rolls max) - Container : standing - Unloading : carefully
Handling	Trolley	Trolley	Trolley
Transport & Downloading	Standing Let labels visible ! Acclimatization 48h	2m: standing, +2m: laying Let labels visible ! Acclimatization 48h	2m: standing, +2m: laying Let labels visible ! Acclimatization 48h
Installation			
Tooling	Specific tools: long scribber, joints scribber, edge trimmer, linoleum hammer, spatula B1 for compact and spatula A2 for Silencio	Spatula A1 compact and A2 acoustic	Mix of linoleum and PVC He, you can use some of the tools from both products spatula A1
Subfloor preparation	Same preparation, see rules in each country		
Subfloor conditions	Same conditions, depends on the country, not the product (maximum humidity level with CCM 4,5% in France, 2% for international...)		
Room conditions	Min 18°C in the room Min 15°C on the floor	Min 15°C in the room Min 10-12°C on the floor	35 to 65% of humidity in the room (for acrylic glue)
Installation			
Installation	Long scribber for walls, edge trimmer one side, overlapping one side with joint scribber	Edge to edge tight, when damaged or for overlapping re-cut with steel roller (called also double cut)	Mix of linoleum and PVC He, you can use some of the installation mode from both products
Laying down	Same laying direction (except for Elle design), no coving of edges floor / wall rolls: ≤32lm for compact and ≤30lm for Silencio Carefully, from wall to wall	Opposite laying direction, expect wood (not bambou) rolls: 23 ml Easy, from middle of room	Mix of linoleum and PVC He, you can use some of the laying mode from both products (depends on room)
Cutting	Pre-cut with long and joint scribber + cutting with hooked knife	Free hand along the wall with hooked knife	Mix of linoleum and PVC He, you can use some of the laying mode from both products (depends on room)
Gluing	Compact : wet bonding with lino adhesive, B1 spatula / Silencio: standard bonding with adhesive for PVC , A2 spatula	PVC adhesives, A1 compact and A2 acoustic spatula, finger test to check waiting time	PVC adhesives, A1 compact spatula, finger test to check waiting time
Welding	Lino welding rod (thermo-gluing), 500°C minimum, 2 to 2,5mm grooving deepness and lino speed nozzle, double cut (trim) of the rod, first one after 5 minutes and second one when the rod is cold	PVC welding rod, 400°C, hot speed nozzle, 1,5mm grooving deepness, double cut (immediate and after 5 minutes) of welding rod	
Initial cleaning	Depending on protection of the floor and on dirtiness, clean with neutral detergent and water, stains with adapted chemical product, follow maintenance instructions given by Tarkett.		

INSTALLATION INSTRUCTIONS FOR HARD FLOORINGS

1 WOOD FLOORINGS

Installing the floor

Before you begin, ensure that the sub floor is levelled, firm, dry and clean. The room where you are installing the floor should have the right temperature and humidity. This also applies to the room where you are keeping the packs of wood. The packs should not be opened until immediately before installation.

Underlay material

For a floating floor, i.e. when the floor is joined together without being attached to the sub floor, you should use an underlay material to level the surface and reduce walking noise. Use an underlay with a long life.



A wooden floor is hard, so to increase comfort it is important to install a shock-absorbent underlay. Tarkofoam II and Tarkoflex II have been developed to meet these requirements. Don't forget a vapour barrier to protect against humidity migration you should apply a vapour barrier over the whole sub floor during the installation for certain types of floor. A vapour barrier is a polythene foil that is laid with an overlap of at least 200mm or is sealed with tape. Tarkoflex II combines an underlay and vapour barrier in one product.

Underfloor heating

The heating system has to be a self-limiting system that provides even heating across the whole floor surface. The surface temperature must not exceed 27°C. Floor heating can cause cracks between the floor boards. Beech, maple and basket weave are more prone to movement than other types of wood and underfloor heating is therefore not recommended for use with these floors.

A. FLOATING INSTALLATION

Floating installation

You can install the new wooden floor directly on top of the old one, regardless of whether it is a wooden floor or a plastic floor. On floors with a surface area greater than 12 x 20 metres, we recommend to glued down installation (see next page). When you install a floor the boards must always be laid lengthwise in the room, and an expansion gap must be left at all fixed points such as walls, thresholds, pipes and steps. There must be no contact between floors in different rooms. Large areas of floor must be broken up into smaller areas with the use of expansion gaps.



Two smart solutions from Tarkett make it easy to install your new wooden floor without glue: UltraLoc and 2-Lock

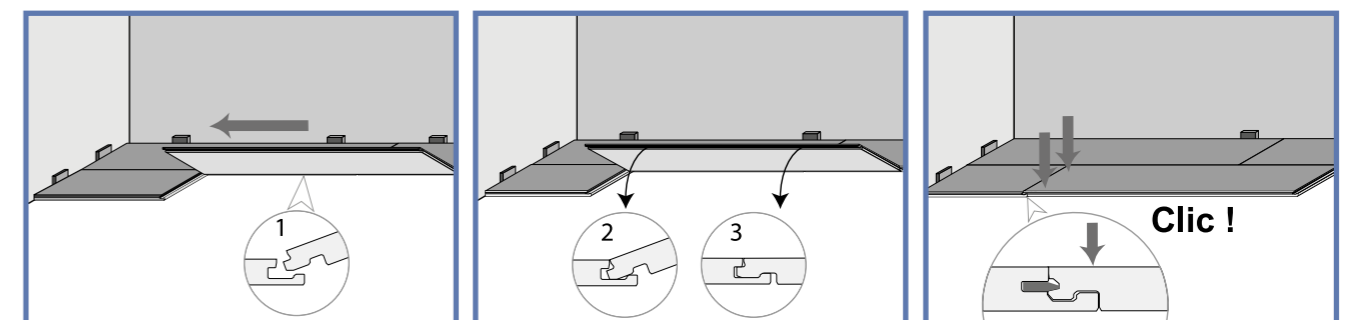

INSTALLATION INSTRUCTIONS FOR HARD FLOORINGS

B. GLUED DOWN INSTALLATION

Conditions

Gluing to the subfloor reduces the movement of the wood floor, and is recommended for laying patterns, covering large areas, etc. Glue down installation is also improving the acoustic properties which are recommended for offices and other segments/areas where it is important to reduce stepping sounds.

The subfloor must be level, stable, dry and clean and must meet the relevant building regulations and norms.

The relative air humidity (RH) must be between 30% and 60% and the temperature must be at least 18°C before, during and after installation. As moisture may appear in a new building, the room should be heated and aired in good time before installation, so that the right indoor climate is achieved.

Tools

In addition to traditional tools we recommend using Tarkett Tarktool and specially shaped Tarkett tapping block along with a serrated adhesive spreader. The tapping block protects the edges of the boards when tapping them together – never use a cut bit of board as a tapping block, as this will chip the edges.

The Tarktool, Tarkett's pull bar, makes it easier to get the last row of boards in place. Cut the boards in such a way that you don't get splintery edges.

Damp proof membrane

A traditional damp proof membrane cannot be laid when the wood floor is going to be glued to the subfloor. If damp is suspected in the subfloor, use an MS-type adhesive and primer (see the Gluing section). Alternatively, lay 0.2mm sheeting onto the concrete floor and then fix a layer of plywood, min 12mm thick, on top. The wood floor can then be glued to the plywood.

Planning installation

Installation direction: If the room is fairly square, the length of the boards should run parallel to the incoming light. In long, narrow rooms it is best to install the boards along the length of the room. Measure the room. If the last row of boards will be narrower than 5cm or if the wall is not straight, the first row of boards should be cut. We recommend that the row of boards is laid out and cut to size before adhesive is applied and the boards are finally installed.

Installing plank: The wear layer of plank comprises one large strip of wood and colour differences between boards do occur. Even minor differences in shade between neighbouring boards may be perceived as disturbing. Therefore, when installing plank flooring, the boards should be sorted. Open several packs and create a gradual colour transition. This avoids the lightest boards being placed next to the darkest.

Expansion gap

Gluing boards to the subfloor reduces the need for an expansion gap. For example, the wood floor can be installed alongside an adjoining stone floor. For practical reasons, we recommend leaving a space of 4-5mm between the floor and the wall. If there are any expansion joints in the subfloor, the wood floor should be split at these.



Joining boards

Traditional tongue and groove: If gluing the floor, boards with traditional tongue and groove must only be glued along the groove at the short end. The boards are joined as usual with a tapping block (shaped) and a hammer.

Ultraloc: Only glue one row of boards at a time. Use the traditional tapping block and tap along the tongue side. Note that Ultraloc boards must not be glued in the profiles. Use a heavy hammer, as one hard tap is better than many small ones.

2-lock: Angled locking systems, with the boards joined by angling in and pressing down into the profile of the previous board.

Different types of subfloors

Wood flooring can be glued to a sub-floor of concrete, particleboard or plywood or onto an existing wood floor. In each case, the subfloor must be sound, level and dry and must meet the requirements in the Conditions section above.

Different types of adhesive

Tarkett Parquet Adhesive MS: A solvent-free MS adhesive that cures in the presence of moisture. It fixes most materials, including metal and marble flooring.

Tarkett Parquet Adhesive D: A dispersion adhesive that is best suited to gluing to particleboard or an existing wood floor. Max RF of 60% in the subfloor.



Description	Tarkett Adhesive D	Tarkett Adhesive MS	Tarkett Primer MS
SAP Mtrl.no	8790102	8790107	8790108
New concrete, acc to norm	X	X	
Old concrete with soft adhesive residues, soft surface		X ¹	1 x (100-150g/m ²)
Old concrete and old adhesive residues		X ¹	1 x (100-150g/m ²)
Old concrete with firm adhesive residues, firm surface	X	X	
Cement concrete with high moisture, up to 90% RH		X ²	2 x (100-150g/layer/m ²)
Underfloor heating		X ²	2 x (100-150g/layer/m ²)
Underfloor heating with high moisture, up to 75% RH		X ²	2 x (100-150g/layer/m ²)
Old woodfloor	X	X ³	
Chipboard acc to norm, free of dust	X	X	
Old chipboard with soft/firm adhesive residues		X ¹	1 x (100-150g/m ²)
Ceramic tiles		X ³	

X¹ = On top of one layer of MS Primer.

X² = On top of two layer of MS Primer.

X³ = Directly after removing old layers.

Adhesive guide

Calculate about 1kg glue/m² ± 200g depending on the subfloor. This chart includes information if primer is needed. Always substrate free of dust is required. To choose right adhesive you have to check even more things. For example, if adhesive is recommended for the type of parquet flooring, moisture in subfloor, etc.

Installation instructions are included in every third floor pack. Detailed instructions can also be downloaded from <http://professionals.tarkett.com>. If you have any further questions, please contact your nearest flooring retailer.

INSTALLATION INSTRUCTIONS FOR HARD FLOORINGS

2 LAMINATE

1. PREPARATION

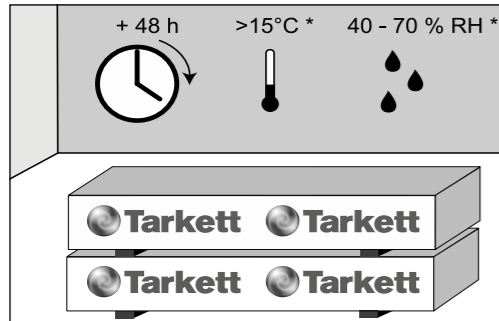

ACCLIMATISING

Allow your flooring to adjust to the temperature of the room in which it is to be installed. The packaged flooring should be placed in the room for a minimum of 48 hours prior to installation.

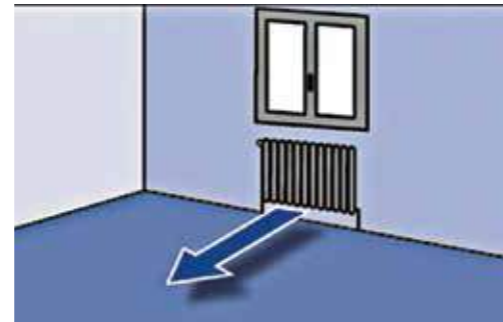

DIRECTION

Always take into account the main source of light and the main direction from which the floor will be viewed. The panels should be laid lengthwise to this direction and never crosswise.

2. INSTALLATION

INSTALLATION BASICS

Laminate flooring should always be laid as a floating floor (i.e. the boards should never be fixed to the sub-floor in any way). For maximum hold, boards should be staggered by a minimum of 30cm and should always be longer than 30cm.

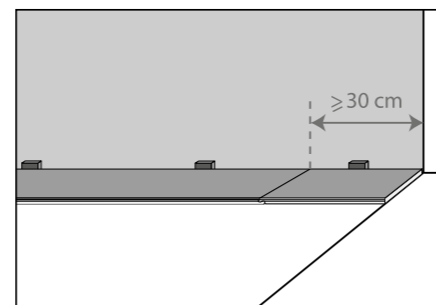

HOW TO INSTAL YOUR LAMINATE FLOORING?*

Glue-free systems. No special tools: a pencil, ruler and saw are about all you need. Always allow for an all around expansion gap of 8-10 mm between the flooring and any fixtures (walls, pipes, door-stops, etc). In corridors and rooms longer and/or wider than 10 meters or between two rooms, expansion provision should be allowed for and covered with a matching transition profile.

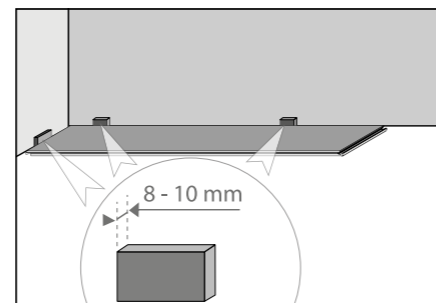

What you need to know about under-floor heating & laminate

Laminate flooring is suitable for installation above under-floor heating systems, provided that the heating element is embedded in concrete or another sub-floor, it is also suitable to be installed on low-temperature water-based under-floor heating systems. The flooring surface temperature should never exceed 28°C.

Laminate flooring is not suitable for installation above under-floor heating foil installed above concrete or any other sub-floor, unless otherwise specified by the under-floor heating manufacturer.

If you are using an electrical under-floor heating system, make sure you have a self-regulating system in order never to exceed 28°C.



2-lock

Fold-down system! It's so easy 2-Lock, it takes 50% less time to install the flooring!

And walk over your flooring as soon as it is laid!

*Always refer to and follow the installation instructions provided with your laminate flooring.

CLEANING RECOMMENDATIONS RESILIENT FLOORINGS

1 INTRODUCTION

Whatever floorcovering is installed, maintenance and cleaning have to be adapted to the usage classification and to the traffic in the area. Methods and frequency will also be defined in this way.

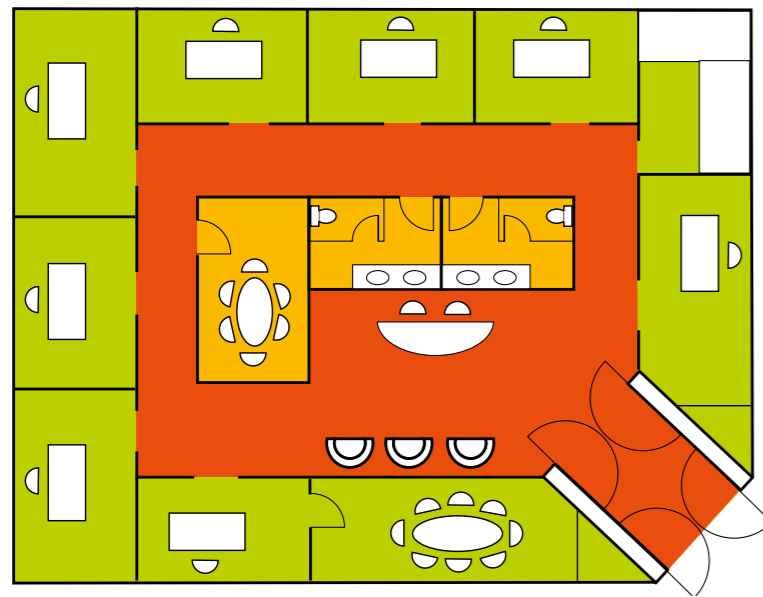

Area	Examples of room
Moderate traffic	Administration, offices...
Medium traffic	Class room, meeting room...
Intensive traffic	Entrance, corridors...

Modern day-room cleaning aims to reduce wet cleaning procedures and replace them with drier cleaning techniques. For example, the use of centrally laundered pre-impregnated mops and the wide application of appropriate machines. This makes work more effective and easier for the cleaning staff, and minimizes environmental impact. Less cleaning chemicals and less fresh water are used.

First step of the cleaning is preventive with entrance matting. About 80% of surface soiling that has to be cleaned off is brought in from outside. And 90% of that soiling can be avoided using an effective and correctly dimensioned entrance mat.

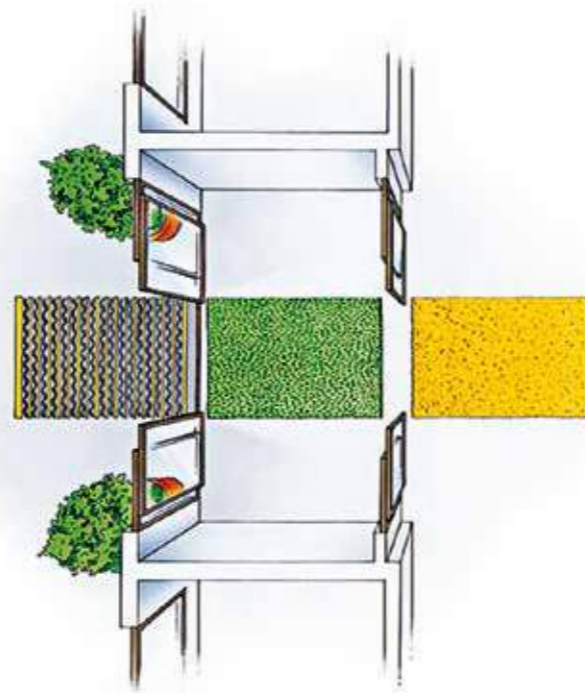

3 ENTRY ZONES REDUCE CLEANING COSTS

2 DEFINITION

SOILING:

Cleaning consists into eliminating soiling:

- non sticky: dust
- sticky: grease
- incrustrated dirt: scale and rust

Soiling can be splitted into 3 groups:

	1	2	3
	Organic soiling	Mineral soiling	Microbiologic soiling
Examples	Blood, food, paint...	Dust, scale, rust...	Bacteria, fungi...
Characteristics	Can be removed easily if not incrustrated.	Ease the deposit of other soiling.	Can develop

DETERGENTS:

THEIR ROLES:

- to facilitate the removal of soils
- to make soils soluble, so easier to remove
- to avoid soils to re-deposit
- to discolour some stains
- etc.

COMPOSITION:

WATER + SURFACTANT AGENT + ACID OR ALKALINE COMPONENT + SEQUESTRANT + COLORANT + PERFUME

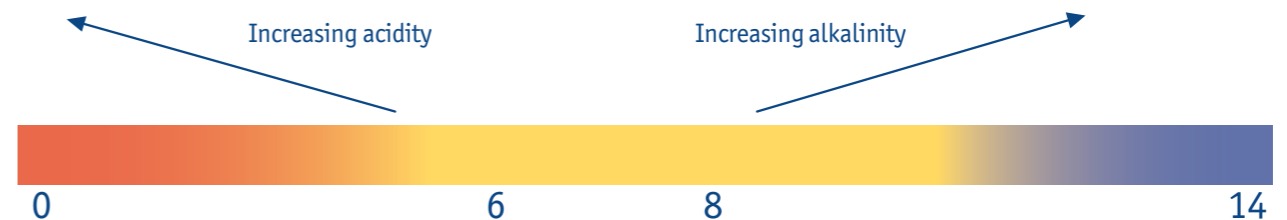

TYPE OF SOILING

Cement	Scale, rust	Mineral soil	Not incrustrated soiling	Organic (not incrustrated)	Incrustrated organic soil	Previous coating
--------	-------------	--------------	--------------------------	----------------------------	---------------------------	------------------

DETERGENT (ACID OR ALKALINE)W

Descaling acid agent	Descaling agent	Acid detergent	Neutral detergent	Alkaline detergent	Degreaser	Stripper
----------------------	-----------------	----------------	-------------------	--------------------	-----------	----------

There are 4 key factors in cleaning and removing stains: Temperature, Time, Chemistry and Mechanics. If you increase one of these factors – temperature, for instance – while keeping the others constant, you get improved washing performances.

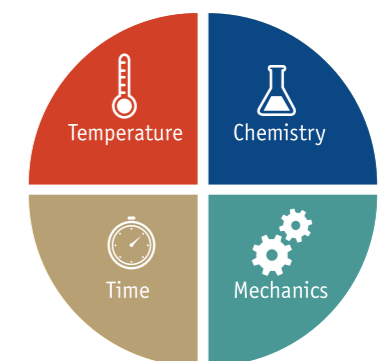

CLEANING RECOMMENDATIONS RESILIENT FLOORINGS

3 TARKETT SOLUTIONS

Cleaning methods will be adapted according to use and traffic but also according to the product type and its coating (surface treatment).



HOMOGENEOUS VINYL:

iQ™: iQ means the absolute minimum of heavy, wet cleaning. No polish or wax is ever needed – just dry buffing – throughout the lifetime of the flooring. Maintenance costs can be reduced by up to 30% compared with traditional cleaning methods.



Premium: PUR reinforced for an excellent life cycle cost. Premium needs no additional surface treatment such as polish or wax when exposed to normal wear and tear. This will have a beneficiary effect on the life cycle cost.



Plus: PUR for easy initial maintenance. Plus products provide the benefits of a PUR surface, for easier initial maintenance and a good base for future maintenance.



HETEROGENEOUS VINYL:

TopClean™: reinforcement which means no wax and no polish and good cleaning and maintenance properties.



TopClean XP™ is a photo-reticulated polyurethane coating. It prevents scratching and abrasion, reduces soiling, removes the need for stripping and polishing and reinforces the floorcovering's resistance to staining.



Safety Clean™: This unique polyurethane treatment is reinforced with slip resistant granules in addition to those within the wear layer of our Safetred ranges to provide lasting performance. Easier to clean and maintain than traditional safety floors.



LINOLEUM:

xf2™: Extremely strong surface toughness, excellent resistance to abrasion, stains and chemicals. No wax or polish needed – no need to strip. Easy cleaning and maintenance, 30% saving on maintenance costs. More than 50% saving on water, detergent and energy. Excellent life cycle cost floors.

4 TYPES OF MACHINES



ROTOCLEANER



COMBI-MACHINE



BUFFER-MACHINE

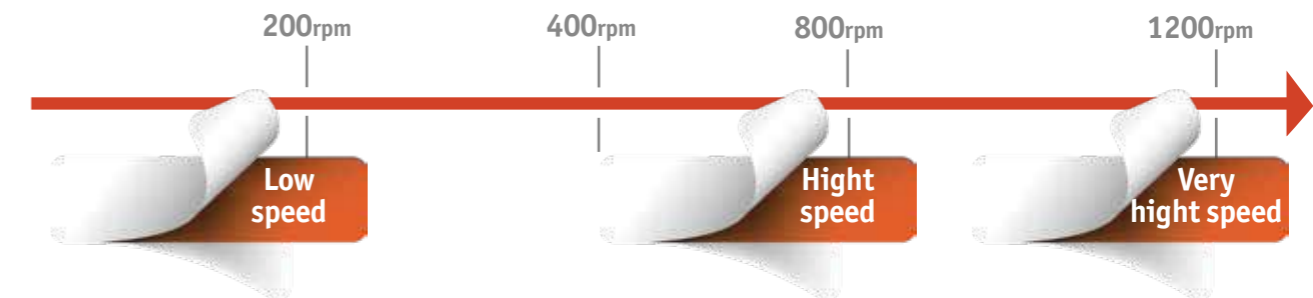







5 TYPES OF PADS

Method / Speed	≈ 120rpm	≈ 330rpm	≈ 1000rpm
First cleaning		●	
Stripping of coating	● ●		
Standard cleaning	●	●	
Scrubbing	●	●	
Buffering		●	
iQ dry buffing		●	







CLEANING RECOMMENDATIONS RESILIENT FLOORINGS

6 ■ CLEANING METHODS SYNTHESIS







■ HOMOGENEOUS PVC: iQ FLOORING

ACTION	MANUAL CLEANING	MECHANICAL CLEANING
Preventive care	 Entrance matting	
Daily & regular cleaning	 Dry mopping Remove dust and dirt with yarn or micro fibre mops, impregnated or not.	 Damp mopping Use a mop dampened with water or detergent solution.  Machine cleaning For best results, clean the floor gently with a combined scrubber/dryer machine and medium hard brushes or preferably red pads.
Cleaning chemicals	If wet cleaning is necessary, use a neutral floor cleaner. Wet rooms may necessitate occasional cleaning with acidic cleaning agents, pH 3 to 5, in order to remove residual lime and soap. Always follow dosage instructions carefully.	
Spot & stain removal	 Treat stains immediately Spot clean by hand with a white/red nylon pad and neutral detergent (solvents should not be used). Work from the outside of the mark towards its centre. Rinse and wipe afterwards with clean water.	
ACTION	MECHANICAL CLEANING	
Periodical cleaning	 Dry buffing For best results, use 330 rpm or more and a red pad to restore surface characteristics. The higher the speed, the higher the gloss.	
Heavy soiling	 Scrubbing + Wet vacuuming + Dry buffing Apply the cleaning solution (a fairly strong cleaning agent, pH 10-11, added to water) to the flooring and let it penetrate for 5-10 minutes. Clean the floor using a heavy scrubbing machine with a red pad. Vacuum away the dirty water immediately. Rinse with clear water. Allow the floor to dry and then dry-buff according to the instructions above.	











■ HOMOGENEOUS PVC: PREMIUM FLOORING

ACTION	MANUAL CLEANING	MECHANICAL CLEANING
Preventive care	 Entrance matting	
Daily & regular cleaning	 Dry mopping Remove dust and dirt with yarn or micro fibre mops, impregnated or not.	 Damp mopping Use a mop dampened with water or detergent solution.  Machine cleaning For best results, clean the floor gently with a combined scrubber/dryer machine and medium hard brushes or preferably red pads.
Cleaning chemicals	If wet cleaning is necessary, use a neutral floor cleaner. Wet rooms may necessitate occasional cleaning with acidic cleaning agents, pH 3 to 5, in order to remove residual lime and soap. Always follow dosage instructions carefully.	
Spot & stain removal	 Treat stains immediately Spot clean by hand with a white/red nylon pad and neutral detergent (solvents should not be used). Work from the outside of the mark towards its centre. Rinse and wipe afterwards with clean water.	
ACTION	MECHANICAL CLEANING	
Heavy soiling	 Scrubbing + Wet vacuuming + Dry buffing Apply the cleaning solution (a fairly strong cleaning agent, pH 10-11, added to water) to the flooring and let it penetrate for 5-10 minutes. Clean the floor using a heavy scrubbing machine with a red pad. Vacuum away the dirty water immediately. Rinse with clear water. Allow the floor to dry and then dry-buff according to the instructions above.	

■ HOMOGENEOUS PVC: PLUS FLOORING









ACTION	MANUAL CLEANING	MECHANICAL CLEANING
Preventive care	 Entrance matting	
Daily & regular cleaning	 Dry mopping Use a mop dampened with water or detergent solution.	 Damp mopping Remove dust and dirt with yarn or micro fibre mops, impregnated or not.  Machine cleaning For best results, clean the floor gently with a combined scrubber/dryer machine and medium hard brushes or preferably red pads.
Cleaning chemicals	If wet cleaning is necessary, use a neutral floor cleaner. Wet rooms may necessitate occasional cleaning with acidic cleaning agents, pH 3 to 5, in order to remove residual lime and soap. Always follow dosage instructions carefully.	
Spot & stain removal	 Treat stains immediately Spot clean by hand with a white/red nylon pad and neutral detergent (solvents should not be used). Work from the outside of the mark towards its centre. Rinse and wipe afterwards with clean water.	
ACTION	MECHANICAL CLEANING	
Restore	 Spray polishing / Spray cleaning To restore worn areas, traffic lanes and scuff marks. Polish systems can be used depending on the requirements and prevailing conditions. It is essential to follow the chemical manufacturer's instructions carefully for the treatment system.	
Heavy soiling	 Scrubbing + Wet vacuuming + Dry buffing Apply the cleaning solution (a fairly strong cleaning agent, pH 10-11, added to water) to the flooring and let it penetrate for 5-10 minutes. Clean the floor using a heavy scrubbing machine with a red pad. Vacuum away the dirty water immediately. Rinse with clear water. Allow the floor to dry and then dry-buff according to the instructions above.	

■ HETEROGENEOUS PVC: TOPCLEAN™ FLOORING







ACTION	MANUAL CLEANING	MECHANICAL CLEANING
Preventive care	 Entrance matting	
Daily & regular cleaning	 Dry mopping Remove dust and dirt with yarn or micro fibre mops, impregnated or not.  Damp mopping Use a mop dampened with water or detergent solution.	 Vacuum cleaning To remove dust and loose dirt. Recommended for large areas and initial site clean.  Machine cleaning For best results, clean the floor gently with a combined scrubber/dryer machine and medium hard brushes or preferably red pads. OR  Spray cleaning To revitalise surfaces with light soiling or traffic wear: mix water, neutral detergent and polymer in the container tank. Suitable speed: 300-500/1000 rpm
Cleaning chemicals	If wet cleaning is necessary, use a neutral floor cleaner. Wet rooms may necessitate occasional cleaning with acidic cleaning agents, pH 3 to 5, in order to remove residual lime and soap. Always follow dosage instructions carefully.	
Spot & stain removal	 Treat stains immediately Spot clean by hand with a white/red nylon pad and neutral detergent (solvents should not be used). Work from the outside of the mark towards its centre. Rinse and wipe afterwards with clean water.	
ACTION	MECHANICAL CLEANING	
Light soiling	 Spray buffing	
Heavy soiling	 Scrubbing + Wet vacuuming Apply the cleaning solution (a fairly strong cleaning agent, pH 10-11, added to water) to the flooring and let it penetrate for 5-10 minutes. Clean the floor using a heavy scrubbing machine with a red pad. Vacuum away the dirty water immediately. Rinse with clear water. Allow the floor to dry.	
Restore gloss – if needed	 Dry buffing Then dry buff to restore the surface gloss. White-beige pad is recommended. Suitable speed: 500-1000 rpm.	

CLEANING RECOMMENDATIONS RESILIENT FLOORINGS







HETEROGENEOUS PVC: TOPCLEAN XP™ FLOORING



ACTION	MANUAL CLEANING	MECHANICAL CLEANING
Preventive care	 Entrance matting	
Daily & regular cleaning	 Dry mopping Remove dust and dirt with yarn or micro fibre mops, impregnated or not.	 Vacuum cleaning To remove dust and loose dirt. Recommended for large areas and initial site clean.
	 Damp mopping Use a mop dampened with water or detergent solution.	 Machine cleaning For best results, clean the floor gently with a combined scrubber/dryer machine and medium hard brushes or preferably red pads.
Cleaning chemicals	If wet cleaning is necessary, use a neutral floor cleaner. Wet rooms may necessitate occasional cleaning with acidic cleaning agents, pH 3 to 5, in order to remove residual lime and soap. Always follow dosage instructions carefully.	
Spot & stain removal	 Treat stains immediately. Spot clean by hand with a white/red nylon pad and neutral detergent (solvents should not be used). Work from the outside of the mark towards its centre. Rinse and wipe afterwards with clean water.	
ACTION	MECHANICAL CLEANING	
Light soiling	 Spray cleaning After dry mopping, spray clean with neutral detergent (red pad). Suitable speed 300-1000 rpm.	
Heavy soiling	 Scrubbing + Wet vacuuming Apply the cleaning solution (a fairly strong cleaning agent, pH 10-11, added to water) to the flooring and let it penetrate for 5-10 minutes. Clean the floor using a heavy scrubbing machine with a red pad. Vacuum away the dirty water immediately. Rinse with clear water. Allow the floor to dry.	
Restore gloss – if needed	 Dry buffing Then dry buff to restore the surface gloss. White-beige pad is recommended. Suitable speed: 500-1000 rpm.	

HETEROGENEOUS PVC: SAFETY CLEAN™ FLOORING





ACTION	MANUAL CLEANING	MECHANICAL CLEANING
Preventive care	 Entrance matting	
Daily & regular cleaning	 Manual brush Brush (medium brush) using a diluted neutral floor cleaner (pH 7-10). Then wipe & rinse with clean water.	 Combined machine with brush (large areas) Use diluted neutral detergent. Speed low 150-250 rpm to higher). OR  Rotoclean machine Spray diluted neutral floor cleaner (pH 7-10) through the machine.
	Wet rooms (Safetred Aqua) may need occasional cleaning with acidic cleaning solution (pH 3-5): Remove lime scale with acidic cleaner (pH 2-4). Wet vacuum and rinse with clean water.	
Spot & stain removal	 Treat stains immediately Spot clean by hand with a white/red nylon pad and neutral detergent (solvents should not be used). Work from the outside of the mark towards its centre. Rinse and wipe afterwards with clean water.	
ACTION	MECHANICAL CLEANING	
Periodical cleaning	 Rotoclean machine Spray diluted neutral floor cleaner (pH 7-10) through the machine.	
	 Machine scrubbing + Wet vacuuming Apply a fairly strong cleaning solution (pH 10-11 after dilution) to the flooring and allow it to act for 5-10 minutes. Scrub the floor using a cylindrical scrub machine or rotary scrubber with medium hard brushes. Vacuum away the soiled water immediately. Rinse with clean water.	

LINOLEUM: xf²™ FINISH FLOORING

ACTION	MANUAL CLEANING	MECHANICAL CLEANING
Preventive care	 Entrance matting	
Daily & regular cleaning	 Dry mopping Remove dust and dirt with yarn or micro fibre mops, impregnated or not.	 Vacuum cleaning To remove dust and loose dirt. Recommended for large areas and initial site clean.
	 Damp mopping Use a mop dampened with water or detergent solution.	 Machine cleaning For best results, clean the floor gently with a combined scrubber/dryer machine and medium hard brushes or preferably red pads.
Spot & stain removal	 Treat stains immediately Spot clean by hand with a white/red nylon pad and neutral detergent (solvents should not be used). Work from the outside of the mark towards its centre. Rinse and wipe afterwards with clean water.	
If necessary	 Wet mopping (for heavily soiled areas) Removes old stains and dirt. Mop the floor using a wrung-out yarn mop head. The mop should not be too wet (to avoid wiping up afterwards). In some cases, it may be necessary to rinse with clean water.	

ACTION	MECHANICAL CLEANING	
Periodical cleaning	 Spray cleaning + Dry buffing Use neutral detergent (pH 5-9). Suitable speed: 600-800 rpm (medium). Dry buff to recover gloss: high-speed buffing machine with white pad. Suitable speed 500-1000 rpm.	
Heavy soiling	 Scrubbing + Wet vacuuming + Dry buffing Apply the cleaning solution (a fairly strong cleaning agent, pH 10-11, added to water) to the flooring and let it penetrate for 5-10 mn. Clean the floor using a heavy scrubbing machine with a red pad. Vacuum away the dirty water immediately. Rinse with clear water and allow the floor to dry. If necessary dry buff (white pad) to restore gloss. Suitable speed: 500-1000 rpm.	

WETROOM CONCEPT:

ACTION	MANUAL CLEANING	MECHANICAL CLEANING
Daily/weekly	 Wet brushing with neutral detergent (pH 6/8).	 Simply wipe with a sponge and clean water. A brush with soft bristles can also be used. Never use abrasive pads.
Monthly	 Wet brushing (bristle brush) with alkaline detergent (pH 8/10). Occasionally, it may also be necessary to use disinfectants, degreasing and/or descaling agents. Then rinse with clean water.	 Clean with a brush (soft bristles) and neutral detergent (pH 6-8) diluted in warm water. Rinse with clean water. We also recommend a general clean from time to time using a detergent that can be used diluted in water in a higher concentration, followed by rinsing with clean water.
Spot & stain removal	 Treat stains immediately Spot clean by hand with a white/red nylon pad and neutral detergent (solvents should not be used). Work from the outside of the mark towards its centre. Rinse and wipe afterwards with clean water.	



7 OVERVIEW OF MAINTENANCE GUIDES

These are generic instructions. Please refer to each individual maintenance notice per product range and adhesive chart with Tarkett selection as guideline.



■ Heterogenous Vinyl - Light Traffic - Acoustic - TopClean™

■ Heterogenous Vinyl - Light Traffic - Acoustic - TopClean XP™

■ Vinyl Luxury Vinyl Tiles - TopClean XP™

■ Heterogenous Vinyl - Acoustic - TopClean™

■ Heterogenous Vinyl - Heavy Traffic - TopClean XP™

■ Heterogenous Vinyl - Heavy Traffic - R10

■ Vinyl Stairs coverings

■ Homogeneous Vinyl - iQ, Premium

■ Homogeneous Vinyl - Static Control

■ Linoleum xf²™

■ Linoleum Essenza

■ Safety Floorings

■ Wood

■ Laminate

■ Sports - Vinyl floorings Omnisports

■ Sports - Wood floorings

■ Sports - Combined floorings - Vinyl

■ Sports - Combined floorings - Linoleum

CLEANING RECOMMENDATIONS HARD FLOORINGS - WOOD

1 LACQUERED

GENERAL ADVICE

Tarkett's range of care and maintenance products makes maintenance easy and keeps your floor fresh and clean. Respecting the care instructions below will also contribute to extend the life of your wood flooring.

PROTECTION

Gravel, dirt and moisture are every wood floor's enemy. Good doormats outside and inside the outer door reduce the need for maintenance.

Furniture with protective pads and a chair mat under castor wheel chairs reduces the risk of indentation marks and scratches on the floor. Liquid must be wiped up immediately. Wood is a natural material that has different properties depending on wood species. Hardness varies between species that gives different sensitivity to indentation marks. All wood floors tend to change colour on ultraviolet exposure, some more others less. This is a natural process that can't be avoided.

INDOOR CLIMATE

Correct indoor climate and air humidity are important. The relative air humidity (RH) indoors should be kept at 30-60% RH to prevent unusual movement (expansion/shrinking) of the floor. The prevention of excessive moisture (during building construction or normal summer humidity) demands good ventilation. By using an air humidifier, it is possible to prevent excessive dryness during the heating season in winter.

All Tarkett wood floorings can be installed on a self regulated floor heating system. The temperature should never exceed 27 °C on the floor surface including areas covered by rugs.

REMOVING STAINS

Tarkett pre-finished wood floors are very resistant to stains. The general rule is to remove stains, before they dry and set, as quick as possible. Afterwards; wipe clean with a well wrung-out cloth. Consult the stain guide below for the type of cleaner you should use. Never use acetone as it will damage the lacquer!

STAIN	REMOVED BY
Fruit, berries, juice, soft drinks, beer, wine, milk, cream, coffee, tea	Mild ammonia-free synthetic detergent such as Tarkett Bioclean in lukewarm water
Chocolate, grease, whipped cream rubber marks, oil, tar, asphalt	Detergent solution
Ink, felt tip pens, stencils, blacking, paint, crayons, etc	Denatured alcohol
Urine, vomiting	Mild ammonia-free synthetic detergent such as Tarkett Bioclean in lukewarm water
Blood	Cold water



The Proteco surface treatment system includes a complete range of cleaning and maintenance products specially developed for daily and periodic care of Tarkett's wood floors. To guarantee the best results, use only Tarkett's products on your wood floor and follow the directions and instructions carefully.

CLEANING

- For daily cleaning, the floor only needs to be wiped, dry-mopped or vacuum cleaned.
- For more thorough cleaning, use a slightly damp cleaning cloth. String mop heads leave too much water behind and are not recommended. For a perfect result, add a couple of drops of Tarkett Bioclean or mild ammonia-free synthetic detergent to the water.
- To extend the finish of your lacquered floor, we recommend that you maintain it with Tarkett Refresher. The refresher is a water-borne, environmentally friendly care and maintenance product that acts as a re-lacquer for your floor! It cleans and leaves a protective finish at the same time. It also prevents slipping and does not yellow. Using Tarkett Refresher slightly increases the gloss rate. It is also applicable on both Proteco lacquer and on Proteco Natura (matt lacquer). Do not use wax!
- Please note that a matt surface (Proteco Natura) attracts more dirt than a floor with a higher gloss rate (Proteco Lacquer). Therefore, a matt surface needs more frequent cleaning and maintenance than a glossy surface.

2 HARDWAX OILED

To protect your hard wax oiled wood floor and prevent aging Tarkett recommends that you use care and maintenance products from OSMO.

READ INSTRUCTIONS FROM OSMO CAREFULLY BEFORE USING.

STOP THE DIRT AT THE ENTRANCE

Stop the dirt at the entrance with an effective mat system. The more dirt you stop at the door, the less cleaning inside the room. Remember that grit can scratch and damage floors.

INDOOR CLIMATE

The correct indoor climate and air humidity are important, otherwise wood floors can change shape more than usual. You should pay particular attention to this in new buildings. Moisture in the building construction and normal summer humidity demand good ventilation, and possibly heating.

The relative air humidity indoors should be 30-60% RH. During the heating season it can become too dry (less than 30% RH) sometimes. In that case we recommend to use an air humidifier.

GENERAL ADVICE

Osomos products for care and maintenance of hard waxed oiled floors make maintenance easier and further extend the already long life of wood floors.

Please note that different wood species have different qualities such as hardness, sensitivity to indentation and scratching, colour, etc. All wood floors change colour slowly when exposed to light.

REMOVING STAINS

Tarkett hardwaxed oiled wood floors are very resistant to stains. Then general rule is to remove stains as quickly as possible, before they dry and set. Afterwards, wipe clean with a well wrung-out cloth.

Consult the stain guide for the type of cleaner you should use.



CAUTION!

There is a risk of spontaneous combustion when oil products are in contact with textiles. Oily cloths must immediately be put into water or burned. In case of contact with eyes, rinse immediately with water. Keep away from children.

STAIN	REMOVED BY
Fruit, berries, juice, soft drinks, beer, wine, milk, cream, coffee, tea	Osmo Wash and Care
Chocolate, grease, whipped cream rubber marks, oil, tar, asphalt	Osmo Liquid Wax Cleaner / Spray
Ink, felt tip pens, stencils, blacking, paint, crayons, etc	Osmo Liquid Wax Cleaner / Spray
Urine, vomiting	Osmo Wash and Care
Blood	Cold water

CLEANING

- For daily cleaning, the floor only needs to be wiped, dry-mopped or vacuum cleaned.
- For more thorough cleaning, use a slightly damp cleaning cloth. String mop heads leave too much water behind and are not recommended. For a perfect result, add a couple of drops of Tarkett Bioclean or mild ammonia-free synthetic detergent to the water.
- To extend the finish of your lacquered floor, we recommend that you maintain it with Tarkett Refresher. The refresher is a water-borne, environmentally friendly care and maintenance product that acts as a re-lacquer for your floor! It cleans and leaves a protective finish at the same time. It also prevents slipping and does not yellow. Using Tarkett Refresher slightly increases the gloss rate. It is also applicable on both Proteco lacquer and on Proteco Natura (matt lacquer). Do not use wax!

CLEANING RECOMMENDATIONS HARD FLOORINGS - LAMINATE



CLEANING, SO EASY!

REGULAR CLEANING
vacuum and dry-mop.



OCCASIONAL CLEANING
Damp-mop with soft detergent suited to laminate and dry-mop afterwards.



STAINS

Remove stains, spots, etc. as they occur. Rub the stain with a clean, dry mop moistened with a dedicated cleaning agent. Never spray any cleaning agent directly onto the floor. When using a solvent or concentrated cleaning solution, read the safety advice carefully!

1 BIO CLEAN 1

- Economical and effective general purpose cleaner.
 - Gentle on the skin.
 - Biodegradable.
 - Free from organic solvents, colouring agents and phosphates.
- Code: 8792 120**

DISPOSAL? RECYCLING?

- You can dispose of your laminate flooring in normal household waste, or disposal waste for large quantities.
- Laminate flooring can be reused or recycled as an energy source.

2 REPAIR KIT 2

A complete kit for repairing dents or scratches, in the unlikely event this should happen!
Code: 8264 000

PREVENTION ALWAYS HELPS!

- Place door-mats and foot brushes at all exterior doorway entrances.
- Fix felt protectors under furniture legs.

STAIN	RUBBER, PLASTIC, HEEL MARKS	BLOOD, URINE	NAIL VARNISH, SHOE POLISH, PAINT, INK, LIPSTICK	FRUIT, MILK, BEER	CANDLE WAX, CHEWING-GUM
SOLUTION	Rub the mark with a dry cloth. Use acetone if needed. Once dry, brush it off with a white nylon pad.	Wipe the stain with a slightly damp cloth. If dry, rub it down with a dry nylon pad.	Remove with a cloth soaked in acetone, nail-tar varnish solvent, paint thinner or vinegar essence.	Remove with an absorbent dry cloth. If dry, wipe down with a dedicated cleaning solution (ideally Tarkett Bioclean), then wipe dry.	Once hardened, these should be removed with a blunt plastic scraper.